



Tractors

XERION

5000 / 4500



Working hard to make your job easier.

XERION 5000 / 4500

Test drive the XERION 5000 / 4500.

Some tractors only feel good when they are pushed to their limits. Doing what they are built to do. Like the XERION. Uniquely designed for maximum strength, traction and pulling performance.

And since we listen to our customers, we know that even the best machines always have a little room for improvement: a chassis that is more gentle on the soil, even more impressive engine power and even more user-friendly controls. Test drive the XERION. Making hard work easier.



Pile on the work.



Innovations	4
The TRAC concept	6
Engine	8
Transmission	10
Construction	12
Chassis	14
Ballasting	16
Hitches and PTO	18
Hydraulics	20
Front and rear linkage	22
Cab and comfort	24
Comfort	26
Control concept	28
Digital solutions	30
CSM headland management	32
GPS PILOT CEMIS 1200	34
Data management	36
Maintenance	38
CLAAS Service & Parts	40
Features	42
Technical data	44

Discover the XERION.
xerion.claas.com





Unique construction.

There is nothing quite like the XERION. You'd recognise it instantly: four equal-sized wheels on two steered axles, full-frame construction for carrying enormous loads, continuously variable transmission up to 530 hp and the intuitive operation that you only get from CLAAS.

Six benefits. Endless possibilities.

- Four equal-sized wheels or dual tyres convert engine power into tractive power
- Two steered axles offer five steering modes for a wide range of applications
- Add up to 7.0 t ballast at the front and rear
- The fully load-bearing frame can support loads of up to 15 t per axle
- Continually variable transmission delivering up to 530 hp helps you to reduce fuel consumption
- Operate the XERION intuitively with the CEBIS touchscreen

Power where you need it.

Impressive performance.

CLAAS POWER SYSTEMS combines powerful 6-cylinder Mercedes-Benz engines with a simple drive train. Enormous torque is available with all three machines even in lower engine speed ranges. The XERION 5000 delivers a maximum torque of 2,600 Nm. The low-speed concept reduces the engine idling speed from 800 rpm to 730 rpm.



Designed to save fuel.

- Extremely powerful engines even in the low speed range
- Constant torque curve at high level
- Intelligent cooling with fuel-saving fan speed control
- Radiators can be cleaned on the move by pressing a button to reverse the fan wheel

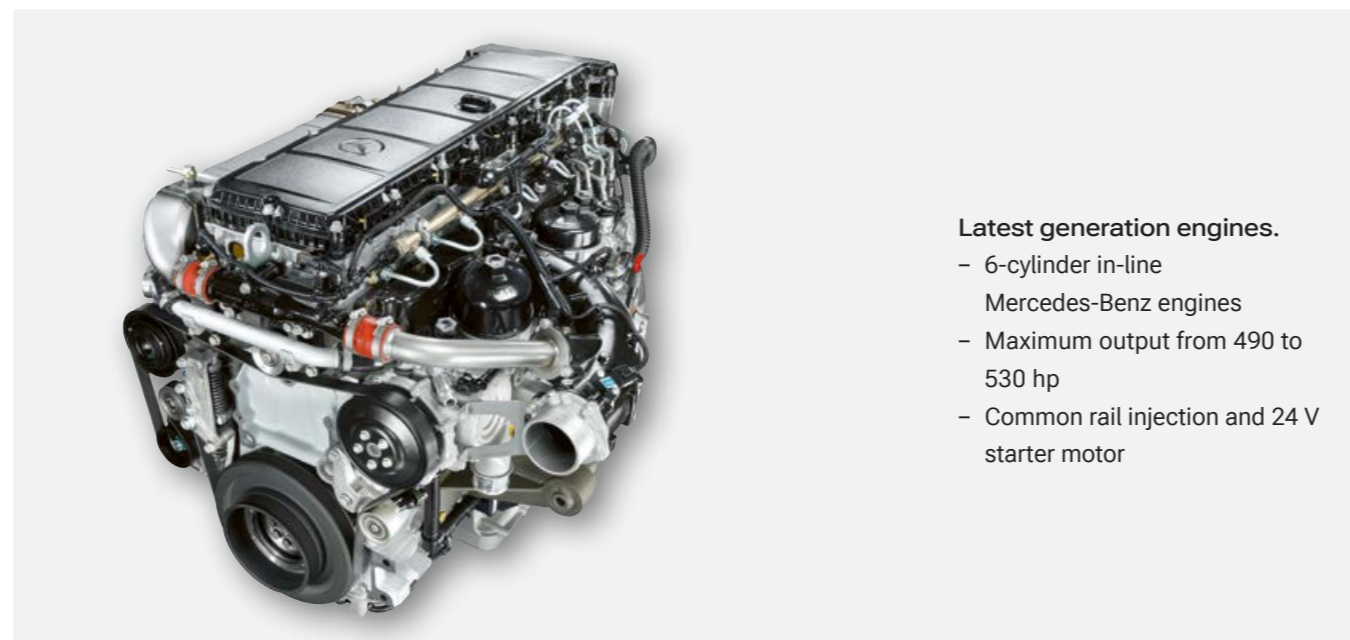

Latest generation engines.

- 6-cylinder in-line Mercedes-Benz engines
- Maximum output from 490 to 530 hp
- Common rail injection and 24 V starter motor

XERION		5000	4500
Number of cylinders		6	6
Cubic capacity	cm ³	12800	12800
Output at nominal engine speed (ECE R 120) ¹	kW/hp	365/496	349/475
Max. output (ECE R 120) ¹	kW/hp	390/530	360/490
Max. torque (ECE R 120) ¹	Nm	2600	2400

¹ Meets ISO TR 14396

Continuously variable transmission for enhanced driving comfort.

Unique in this hp class.

The CMATIC continuously variable transmission from ZF is in a class of its own. From 0.05 to 50 km/h you have the benefit of outstanding driving comfort as well as efficient power transmission provided by a high mechanical component.

The linear drivetrain ensures that engine power reaches the axles and PTO by the most direct route. Selectable longitudinal and transverse differentials provide optimum power transfer.

The accelerator pedal and multifunction control lever are designed for simple and intuitive operation. During field work or at constant PTO speed, the ground speed automatically adapts to the conditions. You can reduce fuel consumption noticeably by making simple adjustments to the engine droop settings.



Short transfer times at 40 or 50 km/h.

The wheeled versions of the XERION can reach speeds of up to 30 km/h depending on the type of transmission. With the cab rotated, you can also travel backwards at up to 30 km/h.

Standing firm.

The XERION slows to a stop as soon as the driver takes their foot off the accelerator. There is no need to apply the brakes – the tractor remains stationary.

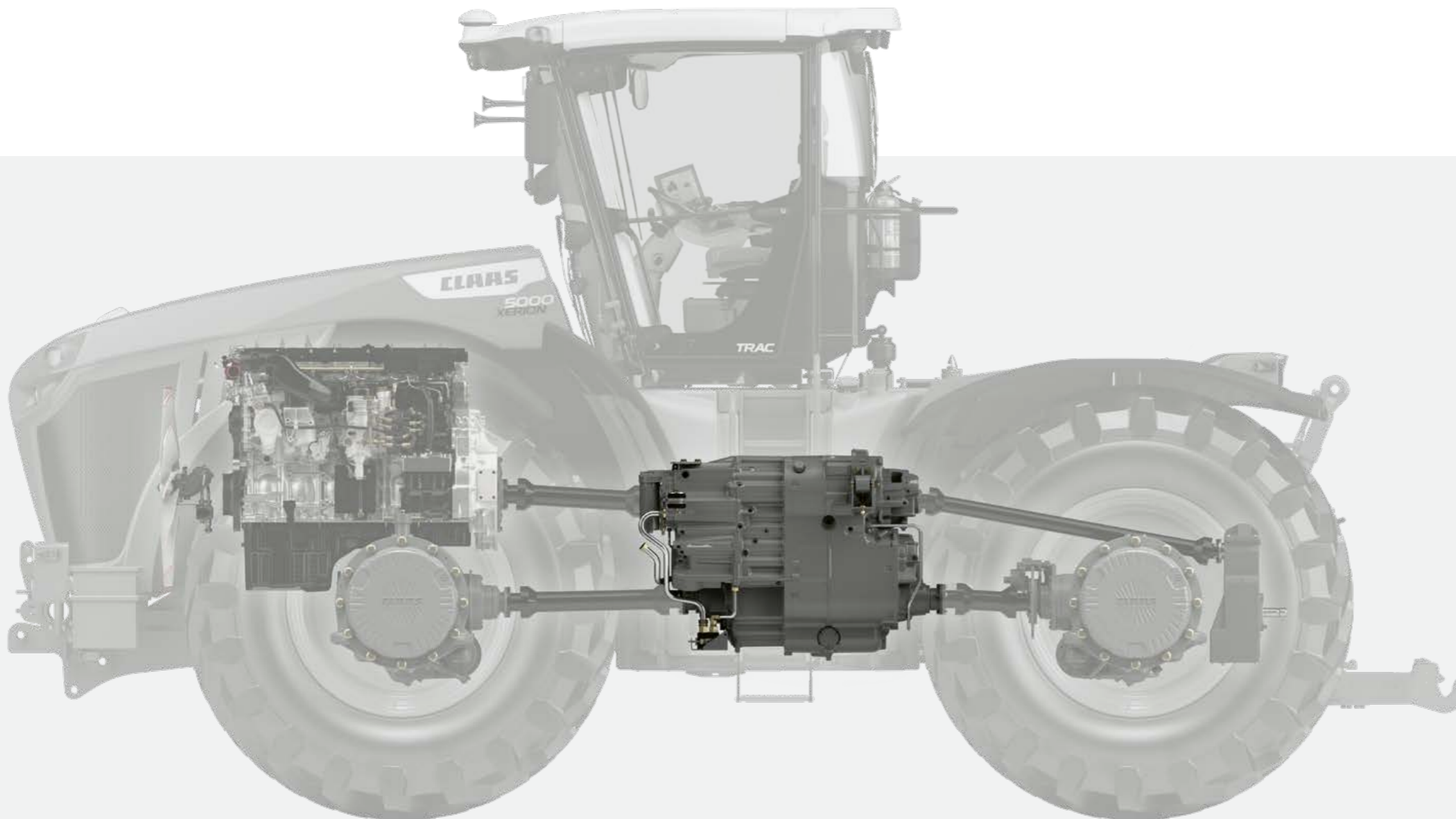

Power equals efficiency.

- CMATIC transmission technology for continuously variable driving comfort from 0.05 to 50 km/h
- Linear drivetrain configuration for direct transfer of engine power
- Permanent four-wheel drive
- Four automatically activated driving ranges for high efficiency
- Large contact area for enormous tractive performance
- User-friendly operation via accelerator pedal or multifunction control lever

Five steering modes make it remarkably agile.

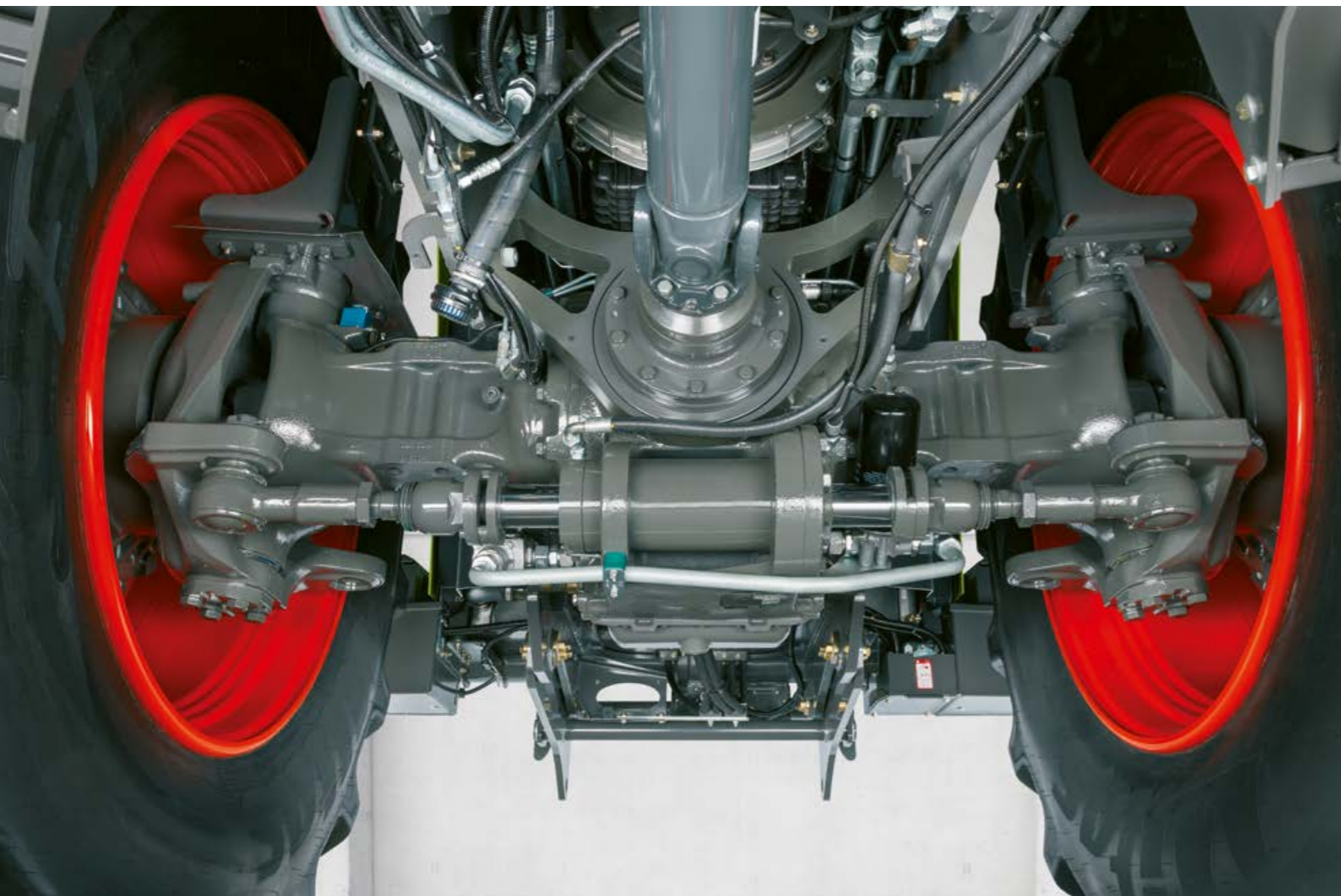

Built for extreme loads.

The XERION is ideal for carrying heavy loads thanks to its unique frame construction. Bolted rather than welded cross-beams in the frame provide greater strength and load-carrying capacity. The heavy-duty axles are designed to carry loads of up to 15 t per axle at speeds of up to 50 km/h. Despite its size and weight, with two steered axles the XERION is remarkably agile and manoeuvrable.

Stability you can count on every day.

- Durable, extremely robust full frame
- Heavy-duty axles with 15 t axle load up to 50 km/h
- Fully integrated linkage with load capacities of up to 8.4 t at the front and 13.6 t at the rear

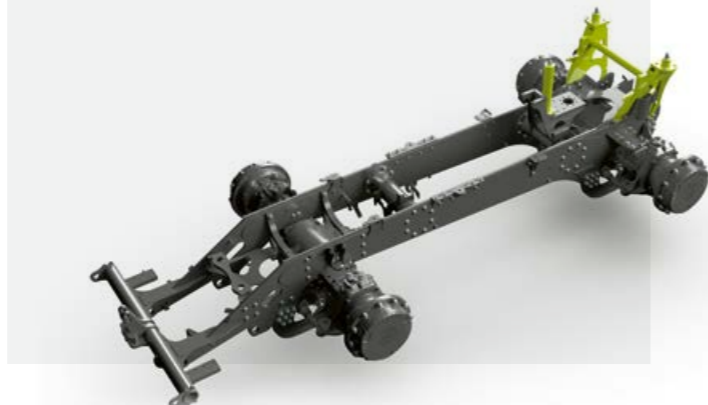

1

Benefit:
High stability on the road

Main applications:
On-road transport
Field transport (transfer vehicle)

The right steering for even job.

The two steering axes on the XERION can be steered in five different ways, and remain active at the headland.

1 Standard steering program.

- Four-wheel and front-axle steering combined
- From 5° steering lock on the front axle, the rear axle follows the front axle electrohydraulically
- The steering lock is continuously reduced from 12 km/h
- Fully locked at 40 km/h

DYNAMIC STEERING option.

- The number of turns of the steering wheel needed to reach maximum wheel lock is significantly reduced according to the speed.
- More comfortable and dynamic turning at the headland

2

Benefit:
Highly manoeuvrable

Main applications:
Tillage
Drilling

2 Four-wheel steering.

- Rear axle is steered at the same time as the front axle but in the opposite direction
- Axles move simultaneously

3

Benefit:
Drift correction keeps tractor on track

Main applications:
Tillage and drilling on a slope

3 Single-sided crab steering.

- Rear axle controlled separately via the CMOTION multi-function control lever

4 Gentle mode (reduced crab steering).

- Rear axle moves along a parallel track to front axle
- 75% of steering lock can be used
- Steering corrected up to 4° by the steering wheel via the front axle

4

Benefit:
Protects the soil (no double rolling action)

Main application:
Slurry spreading

5 Full crab steering.

- Rear axle moves along a parallel track to front axle
- Rear axle steered once via the CMOTION multi-function control lever
- Minor steering corrections possible

5

Benefit:
Maximum utilisation of contact surface

Main application:
Silage clamp work



Two power transmission options.

With the XERION you have two options for transferring its power to the ground via both axles: four equal-sized wheels, or dual tyres that double the contact area.



Four equal-sized wheels.

- With a diameter of 2.16 m
- Footprint approx. 3.7 m² with 900/60 R 42 tyres and 1 bar internal tyre pressure
- No more than 3 m wide with 710/75 R 42 and 750/70 R 44 tyres
- Comfortable road travel at up to 40 or 50 km/h
- Maximum traction and less slip
- Plenty of tractive power

Dual tyres.

- Dual tyres for a high level of soil protection
- Suitable for tyre dimensions 650/85 R 38, 710/70 R 42 and 710/75 R 42
- Rims on outer wheels are firmly bolted to the inner rims with spacer rings

Get the ballasting right for optimum efficiency.

Fuel-efficient ballasting.

Tractors all too often carry too much weight. But over-ballasting does not boost tractive performance – it simply increases fuel consumption. With the XERION it's easy to adjust the ballasting precisely to suit the task. The 400 kg ballast plates can be quickly fitted or removed and firmly secured with quick-release fasteners.

Front ballast.

You can add 3,400 kg of ballast to the front of the XERION. The base weight weighs 1,800 kg and can take up to four additional 400 kg plates. It is available in two versions: one that can be attached to the front linkage and one that is fixed permanently in place.

Rear ballast.

The rear of the XERION can also be ballasted with 3,400 kg. A 1,000 kg fixed (but removable) base plate can accommodate six additional plates each weighing 400 kg. These can be quickly added or removed with a telehandler, wheel or front loader.

Three ballasting tips.

- 1 As much as necessary, as little as possible
- 2 In the field, the need for ballasting decreases as the ground speed increases
- 3 During field work, tyre slip should average more than 6%, otherwise the tractor is carrying too much ballast

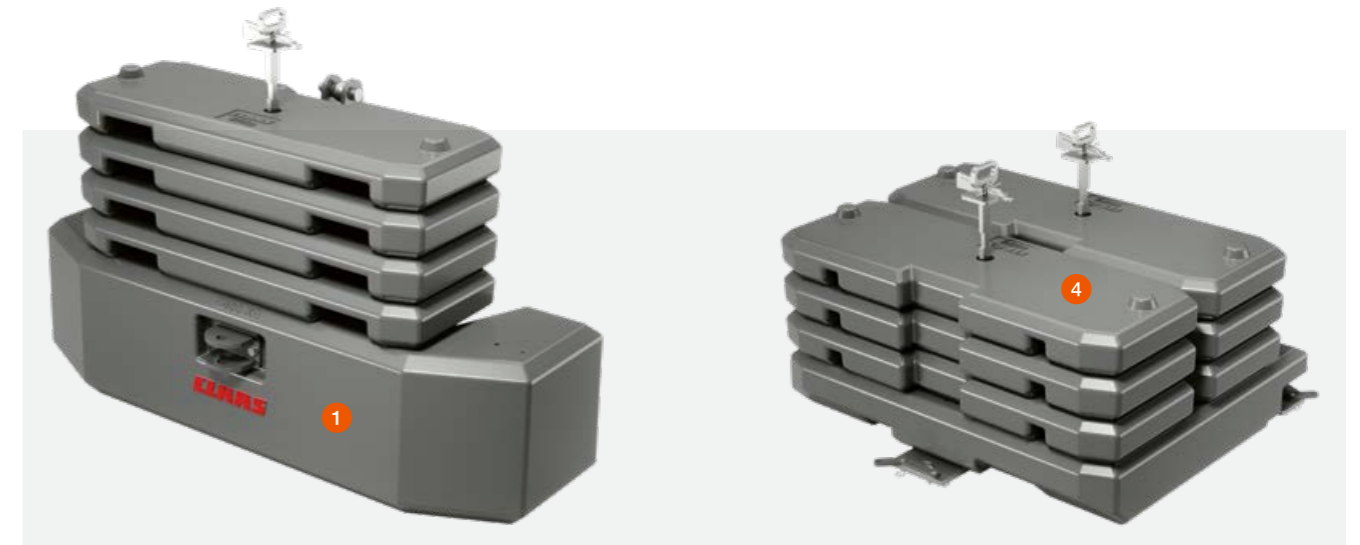

Variable front-mounted ballasting.

Rear ballasting up to 3,400 kg.

- 1 Base weight for the front linkage
- 2 Fixed base weight
- 3 400 kg modular plate
- 4 1,000 kg rear base plate



Max. ground speed under full load	Max. permitted vehicle weight (incl. drawbar load of attachment in t.)
8 km/h	24 t
10 km/h	22.5 t
12 km/h	18.5 t

It's a good idea to estimate in advance the speed at which you plan to work with the attached implement. For example, if you ballast for a speed of 8 km/h and then work at 12 km/h, you're carrying almost 6 t of excess ballast. This has a noticeable effect on fuel consumption.

The right weight for every application.

- Add up to 3,400 kg of ballast at the front and the rear
- Weights are easy to add and remove
- All plates are held securely in place with a quick-release mechanism
- Get the ballast right and save fuel

Creating a strong attachment.



Hitch points and PTO for heavy loads.

With the XERION you can choose from a range of hitching options. Whether drawbar or trailer coupling, all systems are designed for high load-carrying capacity.

When the PTO is running at 1,000 rpm, the XERION develops its output at a reduced engine speed of 1,730 rpm. Thanks to the simple drive train design, much of the rated output is transferred to the PTO stub. This enables you to reduce your fuel consumption even when the XERION makes the full PTO output available.

Rest assured.

- All hitching systems are designed for high load-carrying capacity
- The PTO provides full power even at reduced engine speed
- The PTO stubs can be replaced quickly and easily
- You have a choice of different drawbars with:
 - a 40 or 50 mm diameter locking pin
 - an 80 mm hitch ball



Different drawbar hitches.

With drawbar hitches you have a choice of an 80 mm hitch ball or 38 and 50 mm diameter pin. With three holes, you can vary the position of the attachment point. So whatever the application, you can always maintain the right distance from the rear axle.



High drawbar loads.

The XERION can take on any challenge. With the range of hitch options, it can take a drawbar load of up to 5 t.

- D50 pins (Ø 50 mm)
- D70 pins (Ø 70 mm)



Quick-change PTO stubs.

The PTO stubs can be replaced quickly and securely. Choose from the following sizes:

- 1¼", 6 splines
- 1¾", 20 splines
- 2¼", 22 splines (Ø 57.7 mm)



Hydraulic output of up to 442 l/min

The XERION provides ample hydraulic power for demanding applications. The hydraulic circuits can be controlled via the CMOTION multifunction control lever. You can assign all ten function buttons to individual hydraulic functions.

The XERION has a new pump transfer gearbox to satisfy even higher hydraulic requirements. A hydraulic pump with an output of 197 l/min is mounted to the pump transfer as standard. A second hydraulic pump (load sensing) supplies a further 225 l/min for the four, five or six spool valves.

Power Beyond at the rear.

Power Beyond connections with large-diameter lines, flat-seal hydraulic couplings and hydraulic return line provide a high oil delivery rate with low losses.

The XERION has three double-acting spool valves at the front (max. two spool valves if a front linkage is installed). Eight further double-acting spool valves are available at the rear. With quick-release couplings, you can connect and disconnect them rapidly without risk of oil leaks.



Enough pressure.

- Three hydraulic circuits supply your attached or mounted implements reliably and powerfully
- Up to eleven double-acting spool valves available at the front and rear
- The pump transfer gearbox mounted on the engine enables hydraulic outputs of up to 442 l/min
- Power Beyond connections with large-diameter lines maximise flow
- Conveniently controlled via the CMOTION multifunction control lever

Power means versatility.



Power enough for any job.

With an enormous continuous lift capacity of 8.1 t at the front and 10 t at the rear, the XERION handles even very heavy implements effortlessly.

With the CMOTION multifunction control lever you can control the front and rear linkage easily with your thumb without having to move your hand. This high level of operating comfort means that on long working days you can work quickly and accurately without tiring.

Equipped for any challenge.

- Continuous 8.1 t lift capacity at the front and 10 t at the rear
- Vibration damping for safe and comfortable working
- Convenient control via the CMOTION multifunction control lever



8.1 t lift capacity at the front.

The sturdy front linkage (1) is fully integrated into the frame. The lower links fold in easily to reduce the vehicle length.

- Double-acting ram with continuous 8.1 t lift capacity
- Quick and easy to attach front weights

13.6 t lift capacity at the rear.

The rear linkage is equipped with vibration damping and category 4N hooks. For the top attachment point on the 3-point hitch at the rear, you can choose from a mechanical or hydraulic top link.

- Double-acting rams with max. 13.6 t (10 t continuous) lift capacity
- Robust internal reinforcement for high implement stability
- Lower links available with hooks or ball ends



You've got a long day's work ahead.

So make yourself at home.

The more comfortable you feel at the wheel, the more productive you will be at work. That's something all drivers agree on. For the new XERION, we have taken on board many suggestions from professionals; more comfortable seats, heated windows all the way round and intelligent assistance systems are a given. The armrest with integrated CEBIS touchscreen and ergonomic CMOTION multifunction control lever ensures your hand is in a comfortable position, with all functions at your fingertips. Furthermore, the CEMIS 1200 terminal supports you with precision guidance, ISOBUS applications and job documentation.



Comfort and concentration go hand-in-hand.



With 18 work lights with a total light output of 58,640 lumen, the XERION turns night into day.

Comfortable, clearly laid out and quiet.

We have designed the XERION cab so there is nothing to distract you. Virtually no vibrations, exceptional all-round visibility, pleasantly low noise levels. With the CMOTION multifunction control lever and the armrest with integrated CEBIS touchscreen, you can control the tractor intuitively with just three fingers. The new CEMIS 1200 terminal is also within easy reach.

The XERION comfort cab.

- Generously sized cab
- Large, heated windows for a perfect all-round view
- Outstanding sound proofing (only 69 dB max.)
- Comfortable cab suspension
- Intuitive CMOTION multifunction control lever

- 12" CEBIS monitor with touchscreen
- CEMIS 1200 terminal with intuitive user interface
- 3-way adjustable steering column
- Automatic climate control
- 360 degree windscreen wiper on the front windscreen
- Sun blinds on all four sides (optional)
- Lights activated from the steps

It's got everything you need to make your job easier.

- Comfortable swivel seat – with optional leather cover
- Heated windows for good visibility whatever the weather
- Armrest with integrated CEBIS touchscreen for efficient operation
- Intuitive CEMIS 1200 terminal for precise guidance and documentation

The XERION – outstanding ergonomics.

We've listened to our drivers.

We worked with our customers and drivers to develop the control concept specifically for large CLAAS tractors. The driver's arm and hand stays in a relaxed position without tiring. The clearly arranged control and function buttons are labelled with self-explanatory symbols.

Three-finger operation.

The CMOTION multifunction control lever allows you to control complex processes with up to four control functions intuitively using only your thumb, index and middle finger – so you can work in comfort with your hand resting in a natural position.

Everything under control with CEBIS.

The height-adjustable armrest incorporates the 12" CEBIS touchscreen which allows you to navigate the main and sub-menus with ease. All operating states are clearly displayed and you can adjust the machine settings in just a few steps.



1 CEBIS touchscreen.

You can choose between two screen layouts (road or field), each with self-explanatory symbols and colour coding. The DIRECT ACCESS function with the machine silhouette gives you rapid access to the sub-menus. A high-resolution camera helps you to work with inch-perfect precision.

2 CEBIS rotary pushbutton.

Use it to navigate the CEBIS menu reliably even on bumpy ground. The DIRECT ACCESS button takes you straight to the last activated tractor functions.

3 Clearly laid-out control panel.

Use the self-explanatory controls to operate the basic functions. For example, you can switch the PTO or differential lock on or off, control the linkage or position the front and rear linkage.

4 CMOTION multifunction control lever.

The ergonomic CMOTION multifunction control lever makes light work of complex operations at the headland.

All machine functions at a glance.

- Intuitive control concept for efficient work
- Rapid CEBIS navigation via touchscreen or rotary pushbutton
- CMOTION multifunction control lever for three-finger control of the machine
- Clearly laid out controls with self-explanatory symbols
- CEMIS 1200 terminal for efficient precision farming

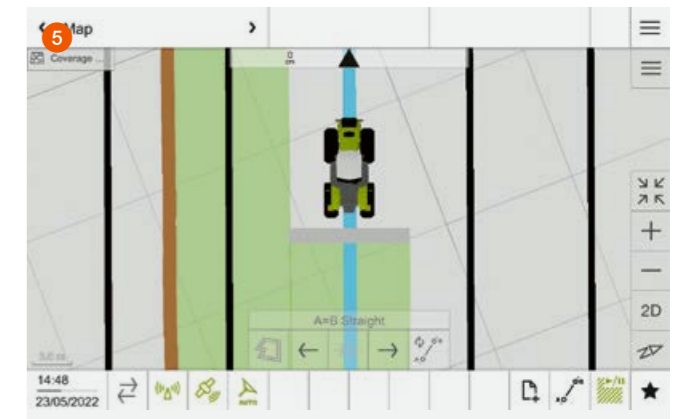

5 Intuitive CEMIS 1200 terminal.

The CEMIS 1200 terminal fits seamlessly into the cab and shares the same intuitive control logic as CEBIS, so you'll soon find your way around. You can use the system on all CLAAS machines set up for GPS PILOT CEMIS 1200, and transfer the terminal and receiver from one machine to another in next to no time.

- Intuitive user interface for outstanding ease of use day and night
- Quick access to all important functions
- Freely configurable working areas for custom control
- Easy activation of new functions allows you to respond flexibly to changing requirements
- Transfer new licences online or activate directly on the terminal
- Automatic section switching with ISOBUS TC Section Control for precise, stress-free work
- Precision farming and documentation with ISOBUS TC-GEO and VRA
- Rapid transfer of all task data via mobile phone connection

The XERION thinks for itself.

Digitalisation is indispensable.

We have three very good reasons for digitalising our machines: we want to help your operators work more confidently, make your work go more smoothly and reduce your costs. With self-learning operator assistance systems, for example, or steering systems that are accurate down to the last centimetre. And with data management that meaningfully connects your systems, machines and work processes.



Perfect turning manoeuvres in next to no time.

CLAAS SEQUENCE MANAGEMENT (CSM).

CSM headland management takes the load off you whenever you need to manoeuvre at the headland. You can run any previously recorded functions simply by pressing a button.

The following functions can be combined in any order:

- Spool valves with time and flow control
- Four-wheel drive, differential lock and front axle suspension
- Front and rear linkage
- Cruise control
- Front and rear PTO
- Engine speed memory



With CEBIS	
Number of storable sequences	Four per implement, up to 20 implements
Sequence activation	CMOTION and F buttons
Sequence display	On CEBIS display
Recording mode	Time- or distance-related
Edit function	Subsequent sequence optimisation in CEBIS



Activate the sequence using the F buttons on the CMOTION control lever

Take it easy at the headland.

- CSM automates your turning manoeuvres
- You can record, vary, optimise and automatically run up to four sequences



Easy to record and run.

Sequences can be recorded on a distance- or time-related basis. In recording mode, clear symbols guide the driver step-by-step through the process of creating the sequence on the CEBIS. A sequence that is running can be paused and restarted simply by pressing a button.

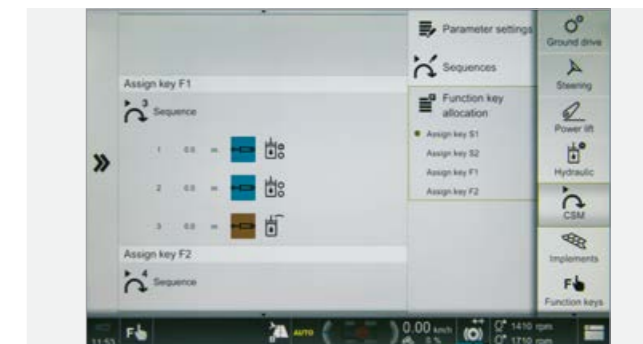

Non-stop optimisation with CEBIS.

Recorded sequences can be changed and optimised in CEBIS at a later date. Steps can be added and deleted or changed and adapted in minute detail, allowing times, distances and flow volumes to be tailored to current conditions. Once a sequence has been recorded, it can be refined down to the last detail in just a few steps.

GPS PILOT CEMIS 1200.

Precision farming made easy.

Precise, future-proof, simple.

Improve the profitability of your farm and simplify day-to-day operations – step into the future with the GPS PILOT CEMIS 1200.

With the GPS PILOT automatic steering system, your machine will seem like it's running on rails: always on the right track, using the full working width with no overlapping.

The CEMIS 1200 fits seamlessly into the cab: with the same intuitive control logic as CEBIS, operators will quickly find their way around.

You can use the system on all CLAAS machines set up for GPS PILOT CEMIS 1200. The terminal and receiver can be transferred from one machine to another in next to no time, giving you complete flexibility and saving money.

Thanks to ISOBUS and standard data exchange formats, the CEMIS 1200 is the way forward for more precision in farming.

Reference track planning.

Plan your reference tracks with ease – record reference tracks spontaneously or use reference track management on the CEMIS 1200 to plan your tracks based on field boundaries. Pre-planned reference tracks can also be transferred to the terminal. CEMIS 1200 provides various different drive modes which enable you to maximise the efficiency of your fieldwork.

In addition, tramline management prompts you to create a tramline in the right position. Tramlines are highlighted in colour on the screen, giving you a perfect overview of your work. You can also activate an acoustic signal.

Benefits:

- Intuitive user interface for outstanding ease of use day and night
- Quick access to all important functions
- Freely configurable working areas for custom control
- The fast and easy way to start fieldwork



Reference track management



Tramline management



Cut your costs per hectare by increasing precision.
steeringsystems.claas.com

Precision guidance.

You need a good correction signal for precise work. It's a given with SATCOR 15¹ as standard for 5 years.

Need even greater accuracy?

Choose the optional SATCOR 3¹ and SATCOR 3 FAST¹ correction signals (± 3 cm).

Absolute precision your top priority?

Choose the GPS PILOT CEMIS 1200 with RTK correction signal for the highest possible repeatable accuracy ($\pm 2-3$ cm).

RTK Bridging.

All RTK correction signals are enhanced by the RTK Bridging function as standard, so if the signal is lost, work can continue for up to 20 minutes with gradually decreasing accuracy.

Difficult topography or mobile phone dead zones in your area?

With RTK Bridging Premium you can carry on working – without loss of accuracy or time limits.

¹ SATCOR 15 / SATCOR 3 / SATCOR 3 FAST powered by Trimble RTX. SATCOR correction signals, RTK Bridging and RTK Bridging Premium are not available in all regions. Together with your CLAAS distributor, we will find the best solution for your individual requirements.

A connected tractor is more productive.

Digitalisation pays.

Digitalisation is a key factor in increasing your productivity and efficiency. Data generated in completely different places can be collected and evaluated centrally. This conserves your resources and improves your business processes.

To enable you to get more out of the XERION and your other machines, CLAAS offers a range of modules which allow systems, technology and working processes to be connected with each other, regardless of the manufacturer. Intelligent digitalisation matched to the requirements of your farm can reduce your workload significantly.

- Transfer and document machine and job data quickly
- Manage individual machines and the whole fleet efficiently
- Analyse working processes in detail and optimise them
- Analyse fields with ease and prepare simple application maps
- Create and manage field track intelligently
- Call up and manage farm data with intelligent farm management software
- Save valuable maintenance and service time with remote diagnostics

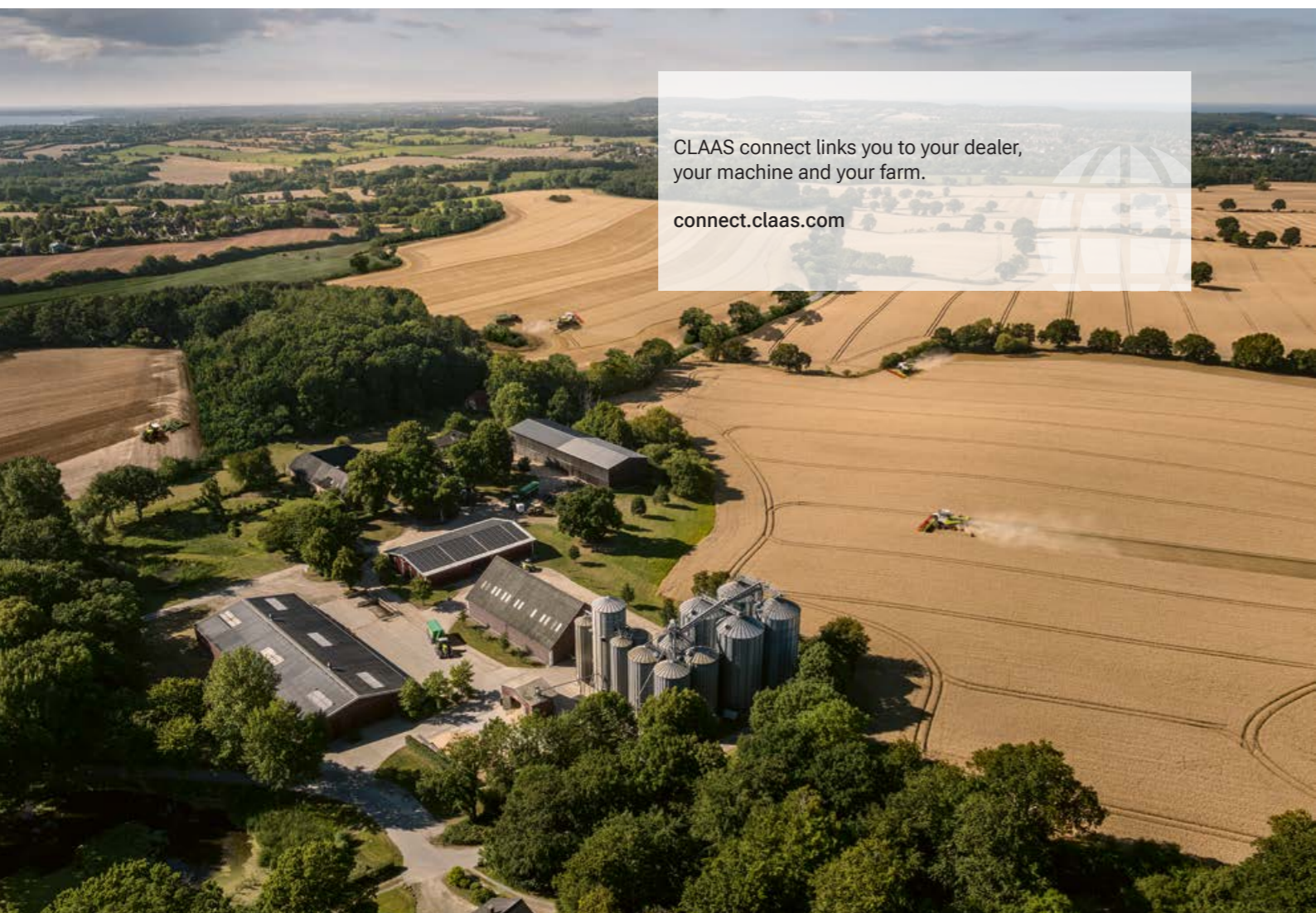

CLAAS connect links you to your dealer,
your machine and your farm.
connect.claas.com

NEW: CLAAS connect.

Everything we do revolves around your success, your machines and your farm. And everything you need is now on one platform – CLAAS connect.

With CLAAS connect, all your farm and machine data are clearly arranged in one place. Compare the performance of your machines on the spot to make the most of your fleet's potential. Manage individual service agreements, maintenance notifications, parts catalogues and operating manuals for all your machines. Order parts and consumables straight from your dealer through the integrated shops.

With track planning, you can easily create tracks for efficient fieldwork and manage them on the platform. Instantly create application maps based on satellite maps for precise, targeted application of seed and fertiliser. Send your jobs complete with tracks and application maps straight from CLAAS connect to the CEMIS 1200 terminal to ensure simple, precise execution on the field.

Discover how documentation runs in the background, recording your fieldwork reliably and automatically. Focus on your work and let CLAAS connect take care of the rest.

Need another machine in addition to your AXION? No problem! You can configure one at any time in CLAAS connect and ask your dealer to arrange a demonstration or prepare an offer.

Three Connect packages to make your job easier.

The Connect packages get you on the right track to manage all your farm's digital tasks. Your CLAAS sales partner and digital specialist will set you up with all the functions you need for your business. Each package gives you a quick overview of your machine and service data in CLAAS connect. The higher level packages help you simplify data exchange between the machine and your office and plan and implement your year-round field work more efficiently.

CLAAS connect packages for tractors.

Connect package	Connect package – Plus	Connect package – Professional
Documentation	Documentation + Steering system	Documentation + Steering system + Precision Farming
<ul style="list-style-type: none"> - CLAAS connect - optional: farm licenses for CLAAS connect - Machine connect 	<ul style="list-style-type: none"> - CLAAS connect - optional: farm licenses for CLAAS connect - Machine connect - GPS PILOT CEMIS 1200 	<ul style="list-style-type: none"> - CLAAS connect - optional: farm licenses for CLAAS connect - Machine connect - GPS PILOT CEMIS 1200 - ISOBUS activations

Not all products are available worldwide. Please contact your dealer to check availability.

Fast maintenance means more time in the field.



One-piece bonnet.

The one-piece bonnet provides rapid access to all maintenance points. Four easily removable side panels provide additional access.

Easy access.

The engine oil filter is positioned within the full frame for easy access. You can access the coolant reservoir when the bonnet is closed. The batteries are safely installed at the front.

A XERION is undemanding.

The machine does whatever it can to minimise downtimes. The engine needs servicing just every 500 hours. And CEBIS tells you when.

Simple radiator cleaning.

When maintenance does become due, it can be carried out quickly and effortlessly. The engine oil filter and cab air filter are very accessible. The radiator assembly can easily be opened and cleaned by the driver as required.

What's more, at the press of a button the driver can reverse the direction of the fan from the cab to blow dust and dirt away from the radiators in seconds. With the automatic fan reverse function, cleaning can be conveniently initiated at a preset time.

Clean engine intake air.

The XERION has an efficient system for precleaning the engine intake air. Cyclones separate out the coarse dirt which is then removed by the exhaust system. The PowerCore® engine air intake filter is extremely robust with high filtration performance.

Maintenance maintains the value.

- 500-hour engine service interval
- One-piece bonnet for rapid access to all maintenance points
- Coolant reservoir can be accessed when the bonnet is closed
- PowerCore® filter for cleaning the engine intake air
- Batteries safely protected

CLAAS Service & Parts
is there for you 24/7.
service.claas.com



On call for you.

Parts and services?

Everything, at the right time.

We're here for you – together, we can achieve the best possible results.

At CLAAS, keeping you operational is our top priority. With our comprehensive range of services, parts and consumables, we ensure that your machines always perform optimally.

Our support includes a wide range of maintenance and repair services available from your dealer, an extensive line-up of ORIGINAL parts and consumables, as well as digital tools which support your planning and decision-making. Confidence comes from knowing you are always ready for action.

Fully covered with MAXI CARE service agreements.

MAXI CARE gives you all-round cover for repairs and maintenance. A comprehensive range of packages ensures that your machines are always ready for action, allowing you to focus fully on your core tasks. CLAAS offers four MAXI CARE service agreements tailored to the needs of your business.



The XERION: built to impress.



Perfected.

- More power: up to 530 hp in the XERION 5000
- More comfort: the CEBIS touchscreen is built into the specially developed armrest
- Long maintenance intervals means longer operating time and lower service costs
- More accuracy: CEMIS 1200 terminal for efficient precision farming

Proven design concept.

- Four equal-sized wheels or dual tyres convert engine power into tractive power
- Full-frame construction can carry enormous loads of up to 15 t per axle at 50 km/h
- Two steered axles offer five steering modes for a wide range of applications
- CMATIC continuously variable transmission helps to save fuel

Powerful drive.

- Powerful 6-cylinder engines are combined with a simple drive train
- Full torque from 1,000 rpm
- Idling speed reduced to 730 rpm in parked position
- CLAAS low-speed concept for maximum tractive power at low engine speeds

Unrivalled comfort.

- The spacious cab offers excellent all-round visibility and sound proofing
- The CMOTION multifunction control lever and CEBIS 12" touchscreen are designed for intuitive operation
- GPS PILOT CEMIS 1200 with ISOBUS implement control and task management



XERION		5000 TRAC	4500 TRAC
Engine			
Manufacturer		Mercedes-Benz	Mercedes-Benz
Number of cylinders		6	6
Cubic capacity	cm ³	12800	12800
Nominal engine speed	rpm	1900	1900
Idle speed	rpm	730	730
Rated output (ECE R 120) ¹	kW/hp	365/496	349/475
Max. output (ECE R 120) ¹	kW/hp	390/530	360/490
Max. torque (ECE R 120) ¹	Nm	2600	2850
Engine speed at max. output	rpm	1600	1600
Engine speed at max. torque	rpm	1300	1300
Fuel tank	l	830	830
Auxiliary tank	l	190	190

CMATIC continuously variable transmission

Transmission type		Hydrostatic-mechanical, split-power	
Output		Four-wheel drive, permanent	
Min. speed at rated engine speed	km/h at rpm	0.05 at 1900	0.05 at 1900
Max. speed at engine speed	km/h at rpm	50 at 1558	50 at 1558
PTO speed at engine speed	rpm	1000 at 1729	1000 at 1729
Automatic PTO engagement/ disengagement		●	●

Axles

Axles		100% lockable, electrohydraulic actuation, lamella construction, with automatic function	
-------	--	--	--

Hydraulics

Type		Load sensing system (pressure- and volume-controlled)	
Max. pressure	bar	200	200
Max. pump capacity with 1 pump (standard)	l/min	197	197
Max. pump capacity with 2 pumps (optional)	l/min	422 (197+225)	422 (197+225)
Max. flow rate per spool valve	l/min	105 / 140	105 / 140
Max. number of spool valves	front rear	2 / 3 5 / 6 / 8	2 / 3 5 / 6 / 8
Hydraulic oil tank	l	120	120
Max. drawable volume	l	80	80

Hitches

Automatic hitch, D38 pin,	max. kg	2500	2500
D40 drawbar	max. kg	3000	3000
D50 drawbar	max. kg	3000	3000

Front linkage

Category		III N, double-acting	III N, double-acting
Max. lift capacity	kg	8400	8400
Continuous lift capacity	kg	8100	8100

Rear linkage

Category		4N, double-acting	4N, double-acting
Max. lift capacity	kg	13600	13600
Continuous lift capacity	kg	10000	10000

¹ Meets ISO TR 14396

● standard ○ optional □ available – not available

XERION		5000 TRAC	4500 TRAC
Cabs			
Display		CEBIS 12" touchscreen	
Suspension		2-point cab suspension, mechanical	
Driver's seat	variants	Fabric / leather, swivels 23° to the right, heated, ventilated, high backrest	
Infotainment	standard / optional	Radio with sound system / radio with sound system and DAB+ incl. subwoofer, gooseneck microphone	
Comfort	variants	Comfort cab, air conditioning, cooled cool box	
Lighting	standard / optional	16x LED 360° - 37,840 lm / 18x HP LED 360° - 59,640 lm	
Digital systems			
Steering system	standard / optional	PS PILOT Ready / GPS PILOT CEMIS 1200 incl. RTK	
Networking	standard / optional	Machine connect 5 years incl.	

Dimensions and weights

Overall length with front and rear linkage in horizontal position	mm	7726	7726
Overall length with front linkage folded and rear linkage in horizontal position	mm	7163	7163
Overall length, without front weight and with rear linkage in horizontal position	mm	7145	7145
Overall height	mm	3791 - 3941	3791 - 3941
Overall width	mm	2540 - 3300	2540 - 3300
Wheelbase	mm		
Kerb weight (with tyres, full tank, 75 kg driver, without front/rear linkage and PTO)	kg	16,000	16,000

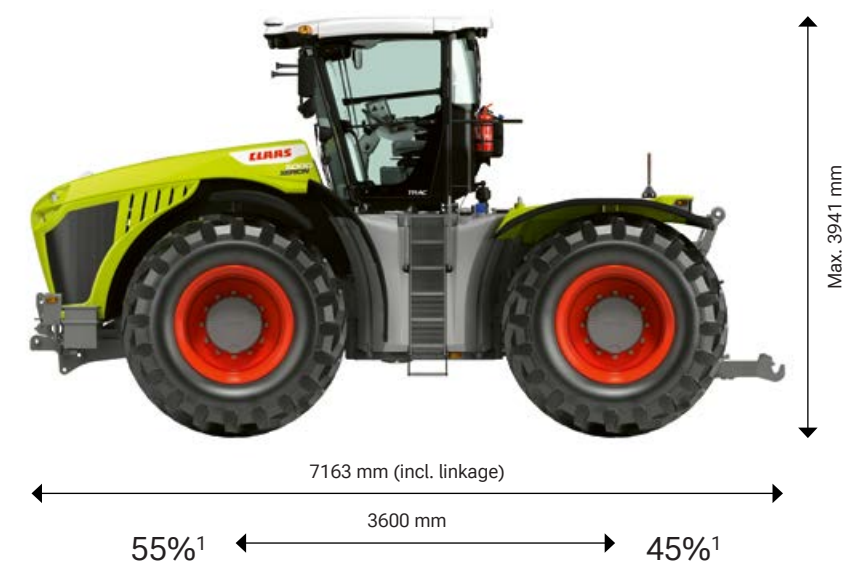

¹ Long wheelbase and balanced weight distribution for more tractive and lifting power

CLAAS continually develops its products to meet customer requirements. This means that all products are subject to change without notice. All descriptions and specifications in this brochure should be considered approximate and may include optional equipment that is not part of the standard specifications. This brochure is designed for worldwide use. Please refer to your nearest CLAAS dealer and their price list for local specification details. Some protective panels may have been removed for photographic purposes in order to present the function clearly. To avoid any risk of danger, never remove these protective panels yourself. In this respect, please refer to the relevant instructions in the operator's manual.

All technical specifications relating to engines are based on the European emission regulation standards: Stage. Any reference to the Tier standards in this document is intended solely for information purposes and ease of understanding. It does not imply approval for regions in which emissions are regulated by Tier.

● standard ○ optional □ available – not available

We want to make you the best in your field.

In everything we do, the focus is on you, our customers. We understand your daily challenges. Together with you, we develop agricultural technology ensuring you can farm successfully and sustainably today and in the future. Our digital solutions simplify complex processes and make your work so much more convenient.



CLAAS KGaA mbH
Mühlenwinkel 1
33428 Harsewinkel
Deutschland
Tel. +49 5247 12-0
claas.com