



Combine harvesters

# LEXION

8800 / 8700 / 8600 / 7700 / 7600

**CLAAS**





## **CLAAS combine harvesters. More than a machine.**

**You're investing in the potential to get the most out of every harvest.**

As the challenges facing farmers grow ever more complex, it's good to know that whatever the conditions, you can always count on optimal support from CLAAS, before, during and after every harvest. When you buy a CLAAS combine harvester, you are investing in optimal adaptability to allow you to work flexibly; in enduring performance to free yourself from constraints, and in the confidence that comes from knowing that you are always operational.

Discover more than a machine.  
[combines.claas.com](https://combines.claas.com)

# The LEXION. Harvest without constraints.

## Reduce your fuel consumption and increase your yield.

You can only operate profitably when every machine in your fleet is working as efficiently as possible. Top performance and maximum efficiency are the most important criteria for success, especially when contending with adverse conditions. The top LEXION models impress with fuel consumption of about 1 litre per tonne at the highest throughput and can deliver their top performance exactly when it is really needed.

Discover the new benchmark for efficiency.



## Increase your productivity in comfort with the new LEXION cab.

The final push of the harvesting season is when you need to be as focused and relaxed as possible. This is why everything in the LEXION's cab is designed for comfort. It is noticeably more spacious at head, shoulder and leg level and features a completely new air conditioning system. The intelligent control system allows you to exploit the full potential of the machine. The bright CEBIS terminal provides you with razor-sharp information so that you can pick up all the relevant data at a single glance. Make yourself comfortable and increase your productivity.

## CEMOS delivers consistent performance and quality.

The CEMOS AUTOMATIC self-learning assistance system supports you actively throughout the entire work process. It checks all the settings on the basis of harvesting parameters such as throughput, standard of cleaning, grain quality and threshing quality while the machine is running and optimises it up to its technical performance limits.



You invest in top performance to free yourself from constraints.

Efficiency	6
Precision	8
Comfort and convenience	10
Reliability	12
Front attachment detection	14
Feeder housing	16
Crop flow	18
APS SYNFLOW HYBRID	20
Threshing unit	22
ROTO PLUS	24
Cleaning	26
Constituents and yield	28
Chaff and straw spreading	30
CLAAS POWER SYSTEMS	32
DYNAMIC POWER	34
DYNAMIC COOLING	36
Ground drive and drive system	38
TERRA TRAC	40
Cab	42
Comfort cab	44
Control system	46
Digitalisation	48
Operator assistance systems	50
Steering systems	56
Data management	58
Maintenance	60
CLAAS Service & Parts	64
Technology in detail	66
Advantages	68
Technical data	70

# Efficient like never before.

APS SYNFLOW HYBRID increases throughput by 10%.  
Page 20

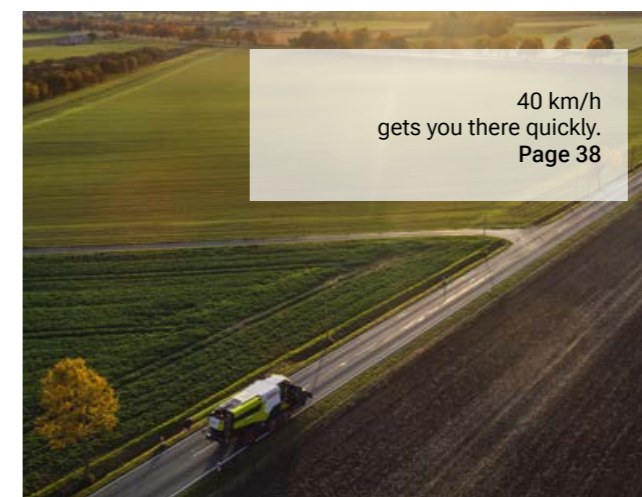
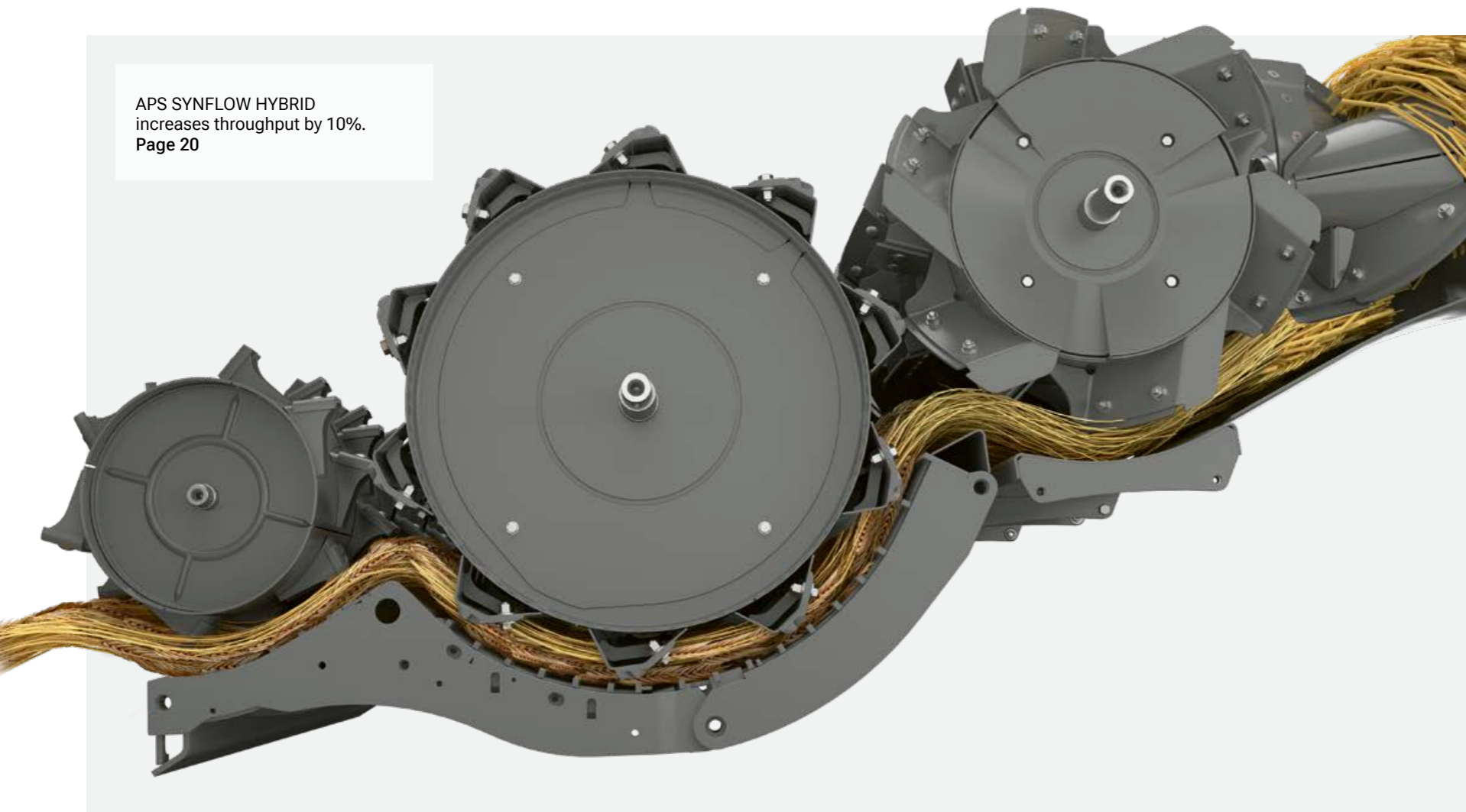

40 km/h gets you there quickly.  
Page 38



**Increase your productivity.**  
Impressively powerful performance translates into profitable efficiency. The top-of-the-range LEXION models deliver their top performance precisely when your operators really need it. This means that you save time and money while benefiting from exceptional productivity.

**Efficiency means success:**

- APS SYNFLOW HYBRID threshing system with maximum separation performance.
- Straight, fuel-saving crop flow.
- Large threshing drum with 755 mm diameter.
- Greater threshing concave separation area with reduced contact angle.
- Parallel threshing concave adjustment with overload protection.
- Grain tank for up to 18,000 l and 180 l/s unloading rate.
- DYNAMIC POWER intelligent engine management.
- 40 km/h top speed for wheeled machine and TERRA TRAC version.
- Cutterbars up to 15.3 m.



18,000 l unloaded in 100 seconds.  
Page 29

DYNAMIC POWER for fuel savings of up to 10%.  
Page 34



Cutterbars up to 15.3 m allow you to work even more productively.  
Page 14

# Precise like never before.

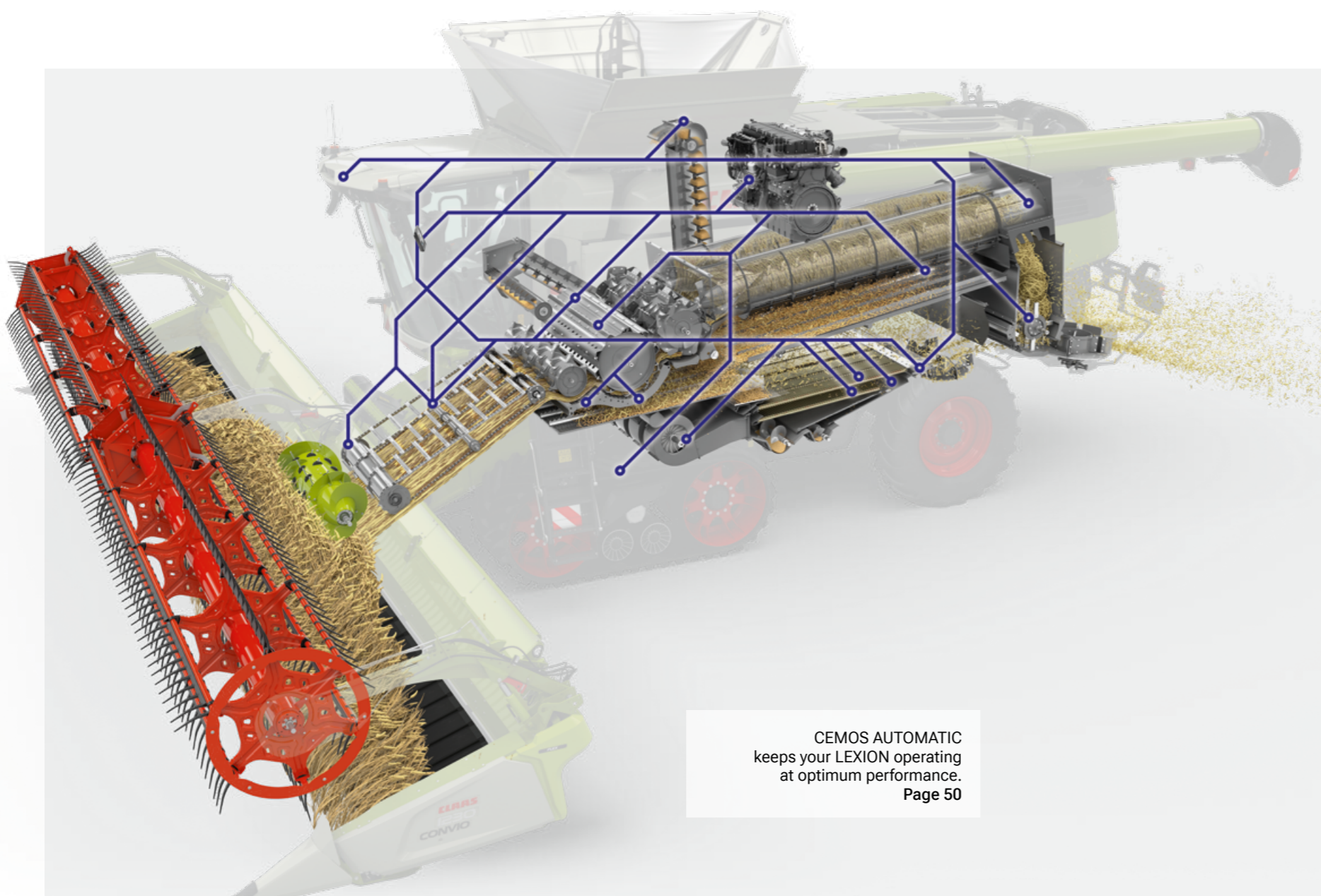

CEMOS AUTOMATIC keeps your LEXION operating at optimum performance. Page 50



QUANTIMETER measures your yield precisely. Page 28



CLAAS connect documents your job and yield data. Page 58



## Make use of its intelligence.

To increase your campaign performance, you need a combine harvester that is able to think for itself and think ahead. In the LEXION, self-learning assistance systems, such as CEMOS AUTOMATIC, are working in the background to support the operator during every minute of the harvesting process.

## Precision means profitability.

- CEMOS AUTOMATIC continuously optimises threshing unit, cleaning system and crop flow.
- CEMOS AUTO CHOPPING optimises straw management and fuel consumption.
- Machine connect transfers your data straight from your machine to CLAAS connect.
- DataConnect allows you to process the data from your machines, regardless of manufacturer.
- CEMOS AUTO HEADER actively controls the position of the reel and the VARIO cutterbar table.
- Measurement of constituents in real time with NUTRIMETER GRAIN.

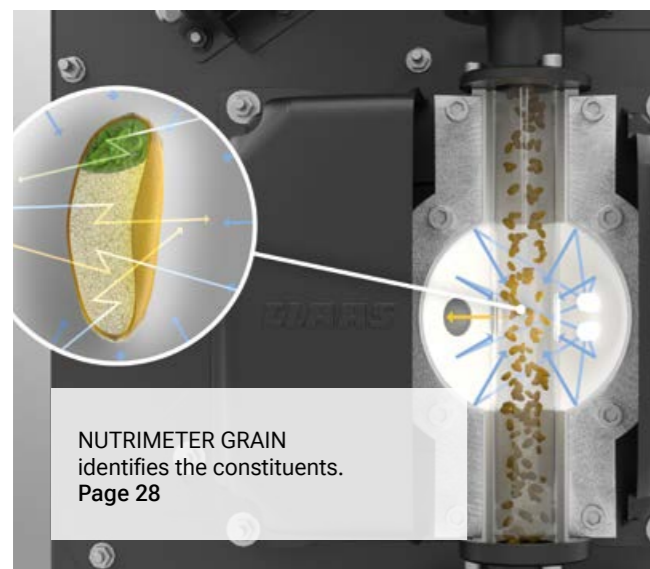

NUTRIMETER GRAIN identifies the constituents. Page 28



CEMOS AUTO CHOPPING was awarded the DLG Silver Medal in 2019. Page 30

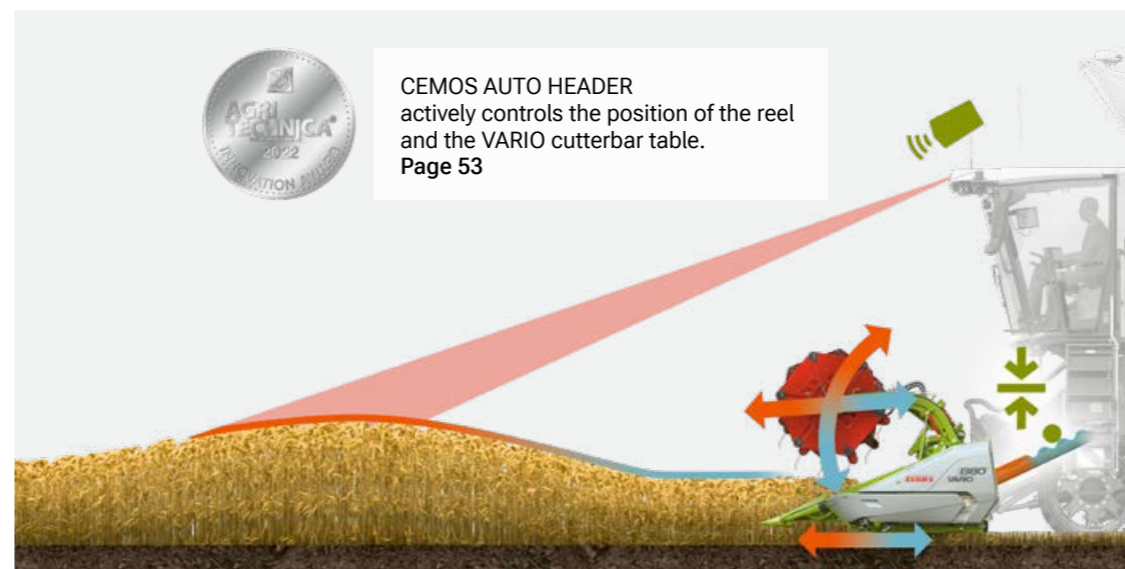

CEMOS AUTO HEADER actively controls the position of the reel and the VARIO cutterbar table. Page 53



# Comfortable and convenient like never before.



LEXION comfort cab provides plenty of space, more legroom and a consistently comfortable, air-conditioned workplace.  
Page 42

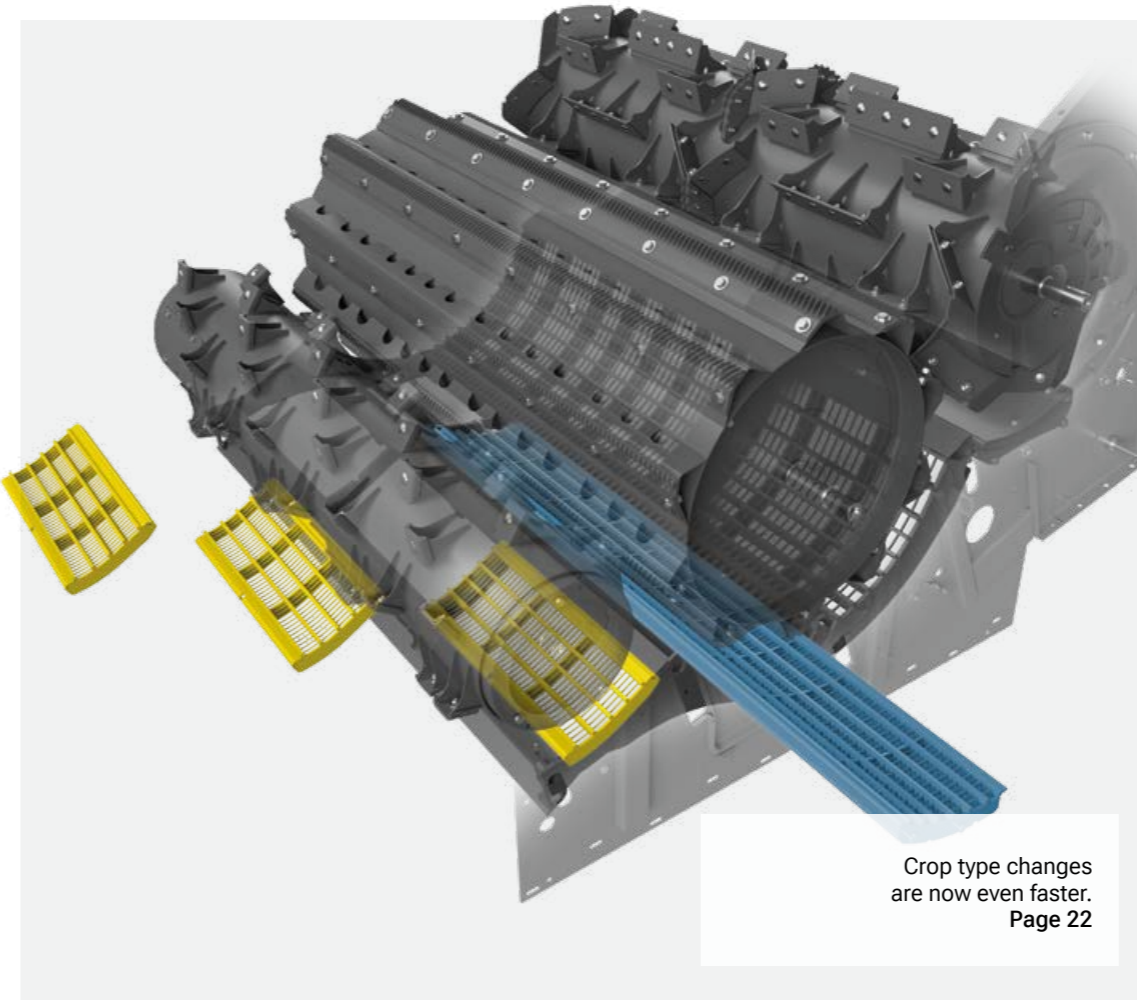

Crop type changes are now even faster.  
Page 22



## Harvest for longer.

The LEXION makes your work in the field easier, or even does away with some of your tasks altogether. Its functions offer operators a maximum level of support so that they remain focused and productive – regardless of how early they start work or how late they stop.

## Comfort improves performance:

- CEBIS terminal with touchscreen and slide controllers for CEMOS AUTOMATIC.
- Fast crop type changes requiring only a few, simple actions.
- Larger grain tank inspection window for fast crop inspection.
- Unloading tube with 105° pivot angle.
- Air conditioning with all-new airflow system keeps your head cool and your feet warm.
- Large storage compartments in the B-pillar and a cool box under the instructor's seat.
- Digital radio with hands-free function.
- LED work lights and maintenance lighting available in a number of different versions and configurations.

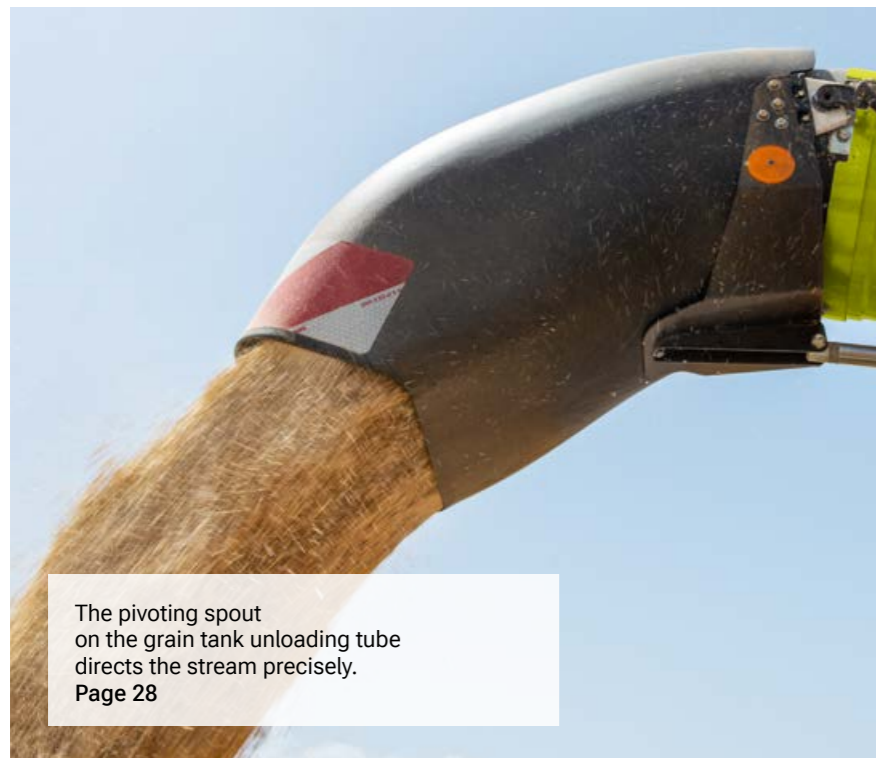

The pivoting spout on the grain tank unloading tube directs the stream precisely.  
Page 28

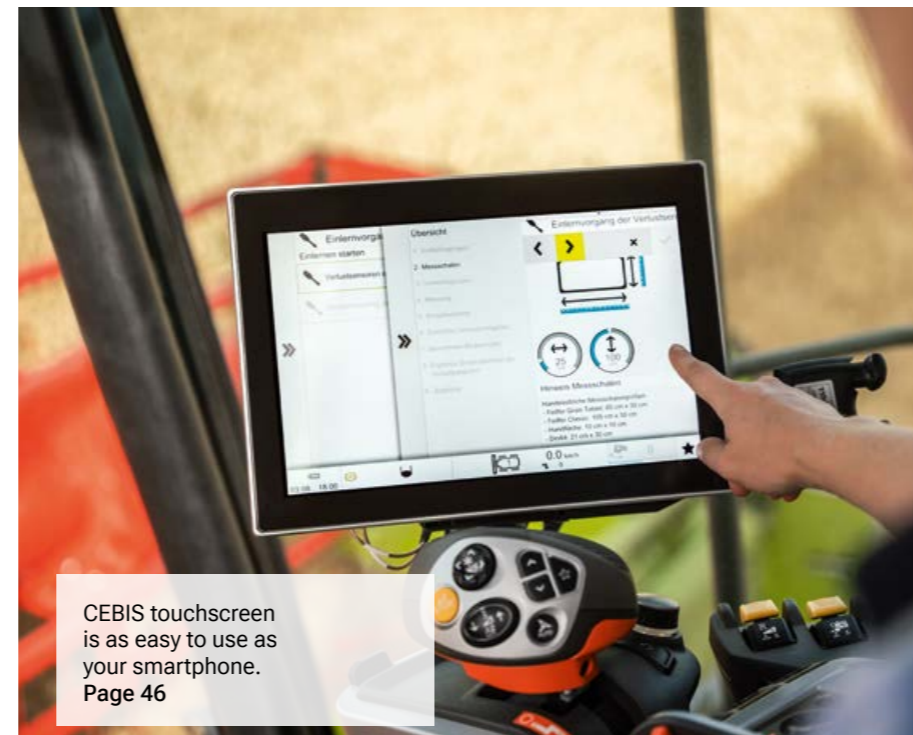

CEBIS touchscreen is as easy to use as your smartphone.  
Page 46



CMOTION multifunction lever designed for intuitive operation.  
Page 46

# Reliable like never before.

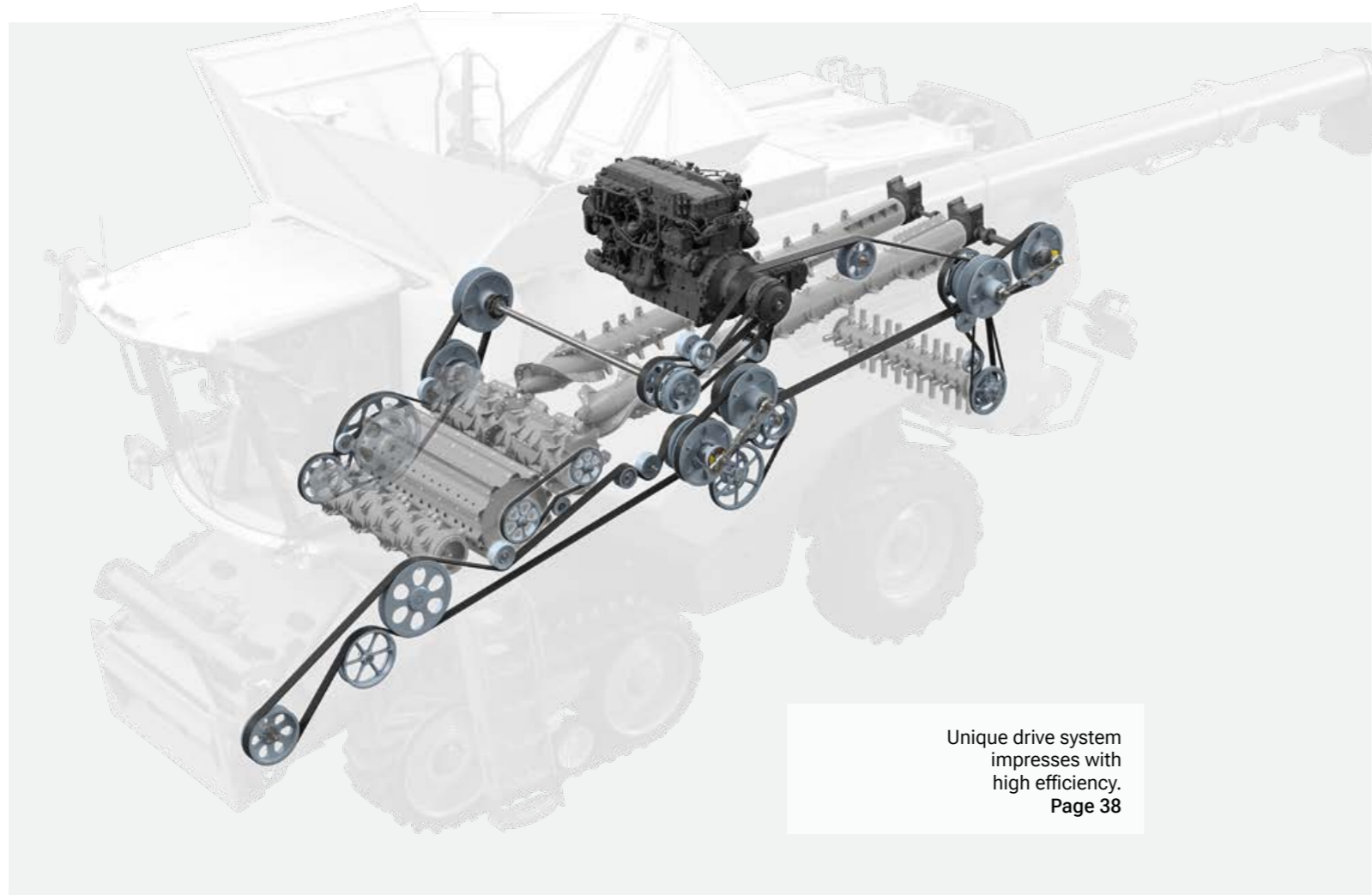

Unique drive system impresses with high efficiency. Page 38

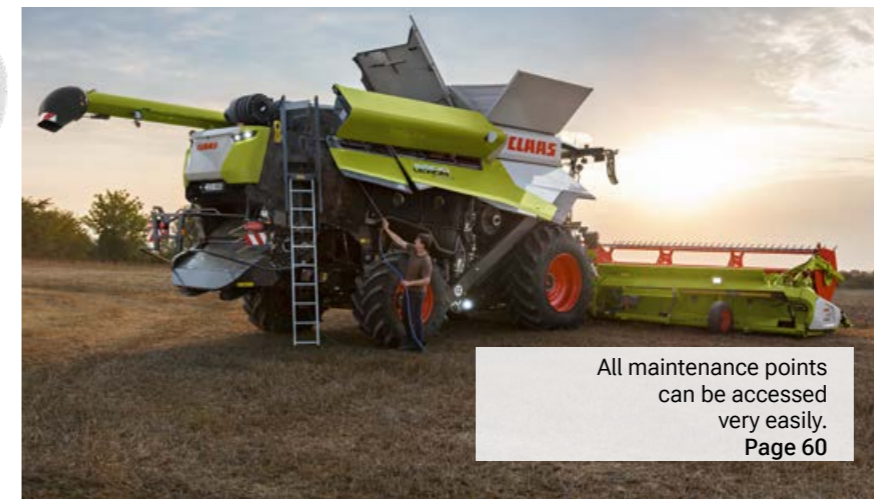

All maintenance points can be accessed very easily. Page 60



**You can count on it.**  
When a combine harvester sets the standards for power and performance, it should do the same with regard to endurance and reliability too. The intelligent drive system of the LEXION is one of the many factors which keep maintenance requirements low and operating reliability high.



PREMIUM LINE components are extra resistant to wear and have a very long service life. Page 62

- Reassuringly reliable:**
- Central lubrication system for all lubrication points, including the variators.
  - Integrated overload protection to avoid blockages in the threshing unit.
  - Automatic parking brake for enhanced safety.
  - Lowered floor plate in feeder housing for higher throughput.
  - Flexible MAXI CARE service products for greater operational reliability.
  - Parts subject to heavy loads in wear-resistant PREMIUM LINE quality.
  - Remote Service for fast and easy maintenance and service support.

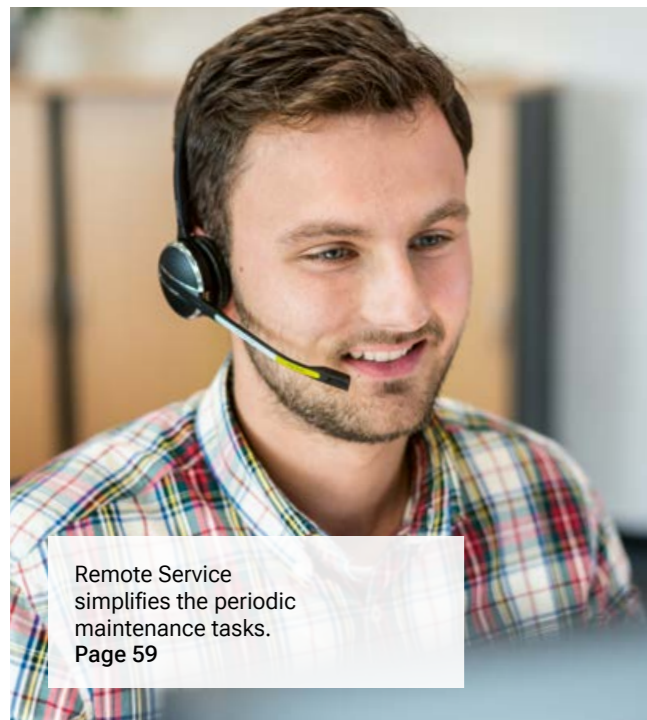

Remote Service simplifies the periodic maintenance tasks. Page 59



MAXI CARE keeps repair and breakdown risks to a minimum. Page 65



HP and V feeder housing allow adjustment of the cutting angle. Page 16

# It detects the front attachments, so you have less to do.

## Excellent cutting right from the start.

With the right cutterbar, you can harvest effectively and extremely productively right from the word go. Automatic front attachment detection helps you to get your LEXION ready for action even faster.

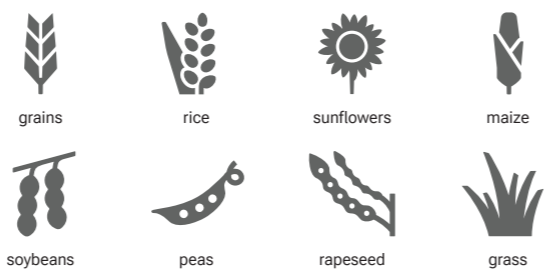

VARIO  
1380 / 1230 / 1080 / 930 / 770 / 680

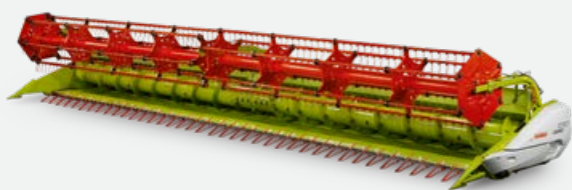

CERIO  
930 / 770 / 680



Folding cutterbars  
C 540



CONVIO / CONVIO FLEX  
1530 / 1380 / 1230 /  
1080 / 930 / 770



MAFLEX  
930 / 770

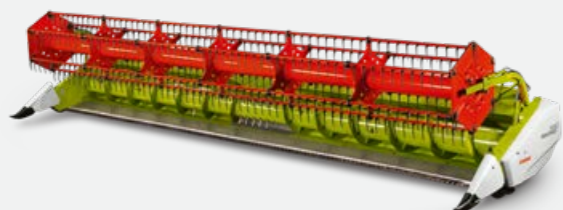

ROVIO  
4.1275 / 4.1270 / 4.880 / 4.875 / 4.870 /  
4.680 / 4.675 / 4.670



SUNSPEED  
1200 / 940 / 750



SWATH UP  
450



### Automatic front attachment detection saves time.

The LEXION configures the key parameters automatically. It does this based on the following information it receives from the front attachment module: cutterbar type, working width, number of sections, reel position, parking position and the AUTO CONTOUR set values for working height and hectare counter.

### You benefit right from the start.

- The combine harvester is ready for harvest in next to no time.
- It is significantly easier to operate.
- The positions of the reel, VARIO cutterbar table and feeder housing are taken into account to rule out the risk of collisions and damage.

### AUTO CONTOUR cuts with greater precision.

AUTO CONTOUR adjusts every cutterbar to the terrain precisely. Sensor bands under the cutterbar are deflected by the undulations and trigger the actuation of the corresponding cutterbar rams. The desired cutting height is programmed via CEBIS.

### Offload your workload.

- AUTO CONTOUR controls and protects the front attachment.
- It makes working with wide cutterbars easier.
- Your operators will appreciate its assistance, especially at night, in lodged grains, on side slopes and on stony ground.
- It increases output and makes using the LEXION even more cost-effective.



Choose the right front attachment.  
[combine-front-attachments.claas.com](http://combine-front-attachments.claas.com)

# The feeder housing takes everything in its stride.



## An optimal crop flow starts with the feeder.

An optimal cutting angle makes an important contribution to ensuring the crop intake is free of losses and blockages, especially when operating under challenging harvest conditions. This is why the feeder housing plays such a decisive role in the success of your harvest. It has to be perfectly matched to the working width, the front attachment, the rotation and the terrain.

You can equip your LEXION with the right feeder housing for every application and requirement. The V feeder housing allows you to perform fast, mechanical adjustment of the cutting angle while the HP feeder housing offers hydraulic assistance so that continuous adjustment to changing harvest conditions can be performed from the comfort of the cab.

## A powerful feeder unit makes you more productive.

- The dust extraction system with an enlarged cross-section delivers even greater cleaning performance.
- The additional fan on the feeder housing prevents dust deposits.
- You can adjust the height of the feed roller without using tools.
- A lowered floor plate allows you to achieve even higher throughputs.



### Feeder housing.

The universal feeder housing with a mechanical tensioning system is available with an open or closed guide roller. It is suitable for all cutterbars up to a working width of 13.80 m or for maize pickers up to 9 m.



### V feeder housing.

The V feeder housing allows you to carry out fast, mechanical adjustment of the cutting angle. This means that you can harvest lodged grain crops, soybeans and grass more easily and with reduced losses as the tendency for the crop to build up is reduced. You can order the V feeder housing ex factory with an open or closed guide roller.

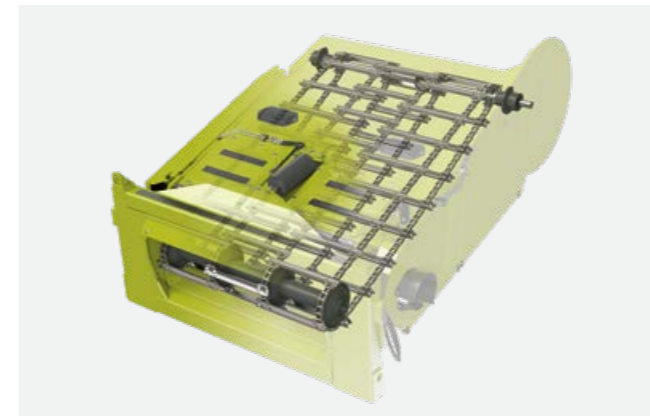

### HP feeder housing.

Using the multifunction lever in the cab, you can perform continuous hydraulic adjustment of the cutting angle of the HP feeder housing from  $-8^\circ$  to  $+11^\circ$  – and you can do so when running at full speed with the front attachment fitted. You can store a separate cutting angle for each of four cutting heights in CEBIS. In this way, you can respond quickly and conveniently to different crop characteristics, types or terrain conditions.



### Everything for safe harvesting.

The front attachment brake offers effective protection against foreign objects. In an emergency, you can stop the front attachment immediately via the multifunction lever. Blockages can be cleared by means of protective reversing with high starting torque. The slow intake feeding after reversing avoids load peaks. All functions can be actuated sensitively.

# Top performance is in its DNA.

## For an even more successful campaign.

With every harvest bringing new challenges every working day, it is reassuring to know that you can count on process technology that is able to cope, whatever the conditions may be. The LEXION has everything needed to deliver top campaign performance. The feeder housing, APS SYNFLOW threshing unit, ROTO PLUS secondary separation and the straw management system work together precisely and ensure the success of your harvest.

## Crop flow at its best.

LEXION operators have always been able to call on an outstandingly capable machine with top performance and efficiency in its DNA. This will continue to be the case in the future.

- APS SYNFLOW HYBRID threshes all crop types.
- CEMOS AUTO THRESHING configures the threshing unit automatically and precisely.
- The ROTO PLUS secondary separation is as flexible as your requirements are varied. The hydraulic rotor flap adjustment capability of CEMOS AUTO SEPARATION ensures that you can get the most out of every field.
- Clean grain is worth real money. JET STREAM cleans the grain intensively.
- AUTO SLOPE and AUTO CLEANING reduce your workload with regard to cleaning. The particular sieve variant fitted is based on your region.
- Collect your grain more efficiently. With a grain tank capacity of up to 18,000 litres and an unloading rate of up to 180 l/s.
- Its straw management is excellent. Even when the machine is operating in strong crosswinds, handling high straw volumes or negotiating side slopes, the radial spreader always deposits the straw precisely.



# APS SYNFLOW HYBRID is clearly more productive.

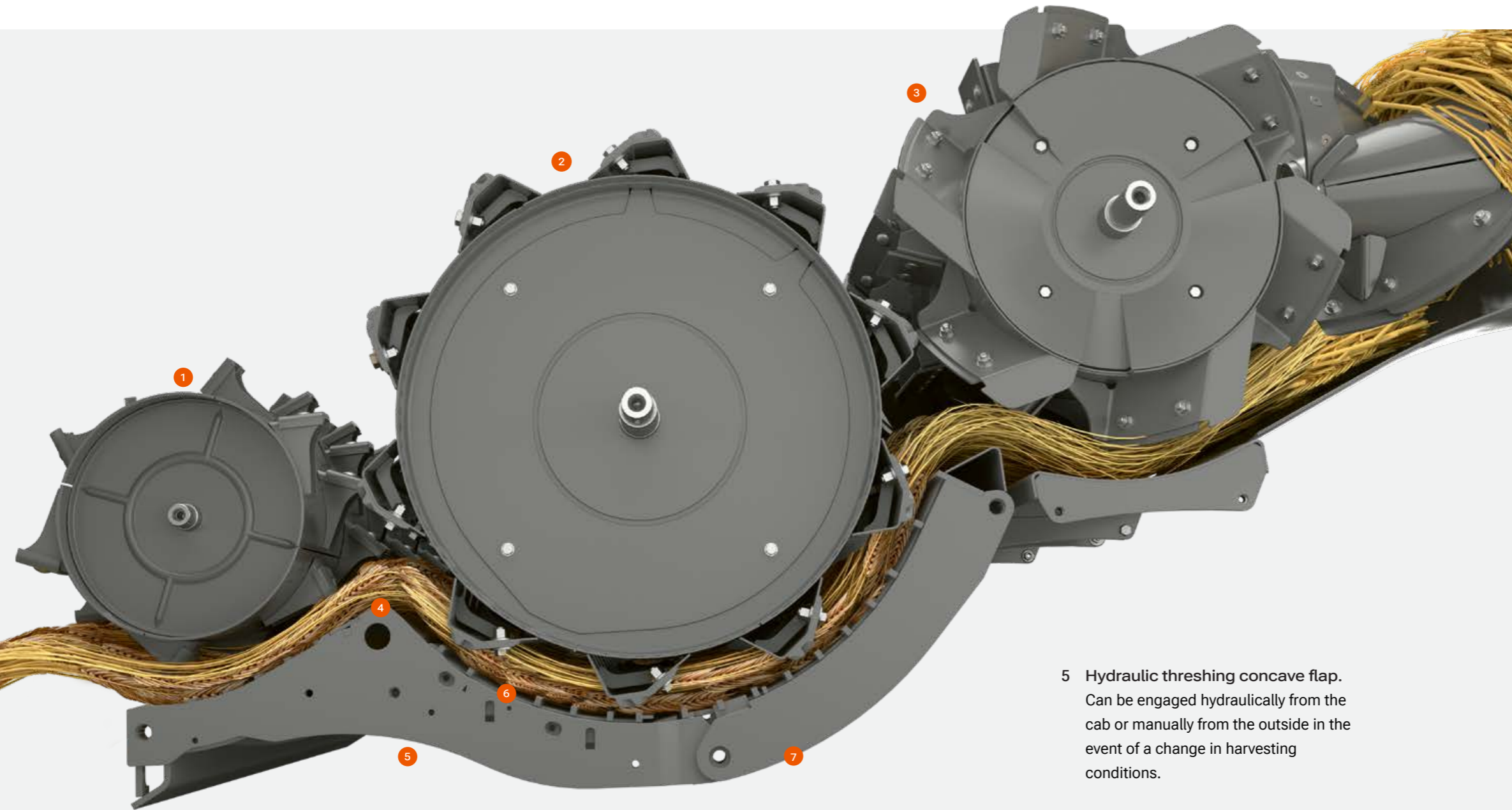

- 1 Maximum separation performance. Smooth acceleration of crop flow to as much as 20 m/s across all concave areas.
- 2 755 mm threshing drum. Large threshing drum for high separation performance and stable throughput.

- 3 600 mm feeder drum. Blockage-free feeding of the harvested material to the rotors.
- 4 Pivoting concave bar. Can be engaged hydraulically from the cab via CEBIS for fast crop type changes.

- 5 Hydraulic threshing concave flap. Can be engaged hydraulically from the cab or manually from the outside in the event of a change in harvesting conditions.
- 6 MULTICROP. Short changeover times and various combination options make it easier for you to change crop types.
- 7 Synchronised adjustment. The preconcave and threshing concave are adjusted in parallel. The drum speed changes are synchronised.

## Straight-line crop flow saves fuel.

The 450 mm accelerator drum in the APS SYNFLOW HYBRID starts an extremely efficient threshing process which allows you to achieve outstanding throughput rates. It accelerates the crop flow smoothly to as much as 20 m/s. In so doing, it generates a high centrifugal force which enables maximum separation performance across all concave areas.

Large drum diameters and small contact angles enable particularly flat transitions between the threshing and feeder drums as well as the rotors. This means that there is a straight, fuel-saving crop flow through the combine harvester. What's more, there are no unnecessary changes of speed or direction of flow. This makes for gentle straw handling and saves fuel.



# APS SYNFLOW threshes every crop.

## Reliable throughput in all harvesting conditions.

In developing the threshing system, we have drawn on our many years of experience. The combination of the tangential APS SYNFLOW threshing unit and the axial ROTO PLUS secondary separation makes the APS SYNFLOW HYBRID threshing unit the trendsetter for its class. Whichever crop you are harvesting, you can look forward to high throughput – with extremely low fuel consumption and top quality chopping.

## Easy actuation of preconcave flap and threshing concave flap.

In order to react to a change in crop type or for flexible adjustment of the friction path in the threshing and separation sections, the operator can engage the preconcave flap and the threshing concave flap manually from outside. The threshing concave flap is also available with optional hydraulic adjustment. When this option is specified, it can be operated conveniently from the cab and is integrated in CEMOS AUTO THRESHING.

## Synchronised speed adjustment.

The threshing drum speed can be matched easily to all conditions and crop types. It can be adjusted – independently of ROTO PLUS – in CEBIS to any setting between 330 and 930 rpm. Changes to the speeds of the accelerator drum, the threshing drum and the feeder drum are synchronised

## Perfect adjustment of threshing unit.

In order to align your LEXION optimally with your business and your preferred crops, six threshing unit versions and three rework kits are available to match the profile of the areas you work. The range allows you to find the ideal threshing unit for rice, maize, beans and grains with high or low yields.

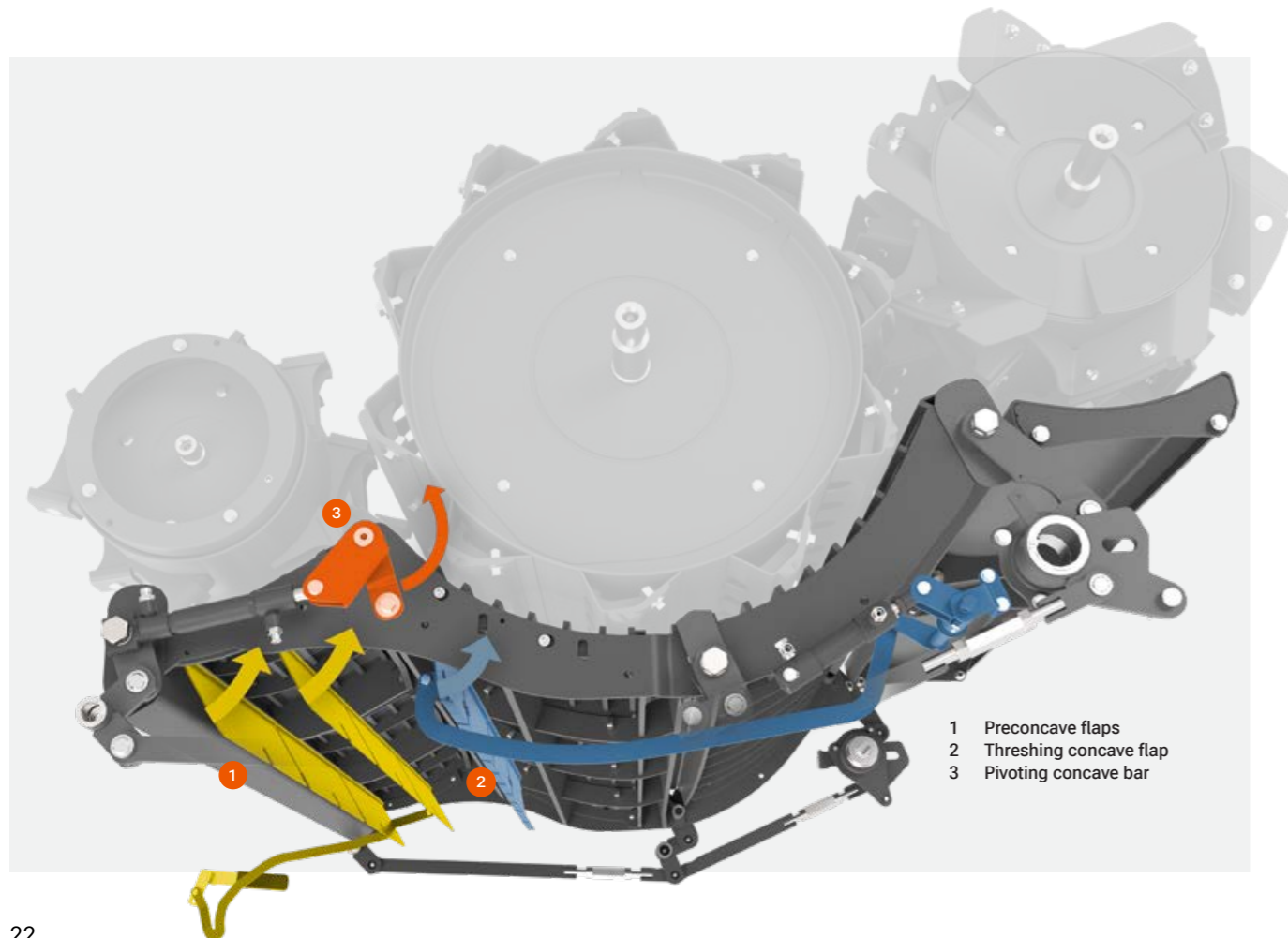

- 1 Preconcave flaps
- 2 Threshing concave flap
- 3 Pivoting concave bar

## Parallel adjustment of threshing concave.

CEBIS allows infinitely variable hydraulic adjustment of the position of the threshing concave. As this involves the parallel and synchronised adjustment of the preconcave, threshing concave and separator concave, you can be certain that the entire crop flow will run evenly while handling the straw gently. Integrated overload protection prevents blockages and protects the threshing unit from damage.

## Hydraulically pivoting threshing concave bar.

For clean threshing under all conditions, including when deawning or decortication is difficult, the threshing concave bar can be pivoted hydraulically via CEBIS. Like the hydraulic actuation of the threshing concave flap, this comfort feature is integrated in CEMOS AUTO THRESHING.

## Change concave segments quickly.

Changeover times from one crop type to another are getting ever shorter. When a changeover is carried out, the main components of the threshing concave remain in the machine. You can quickly change the preconcave segments through the stone trap simply by pulling the threshing concave segment out to the side. The numerous combination options are the key to the unique MULTICROP capability of the LEXION.

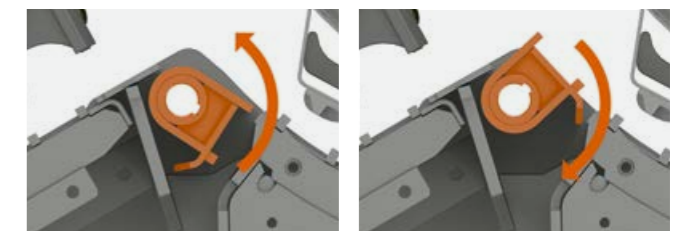

# ROTO PLUS makes the most of your crop.

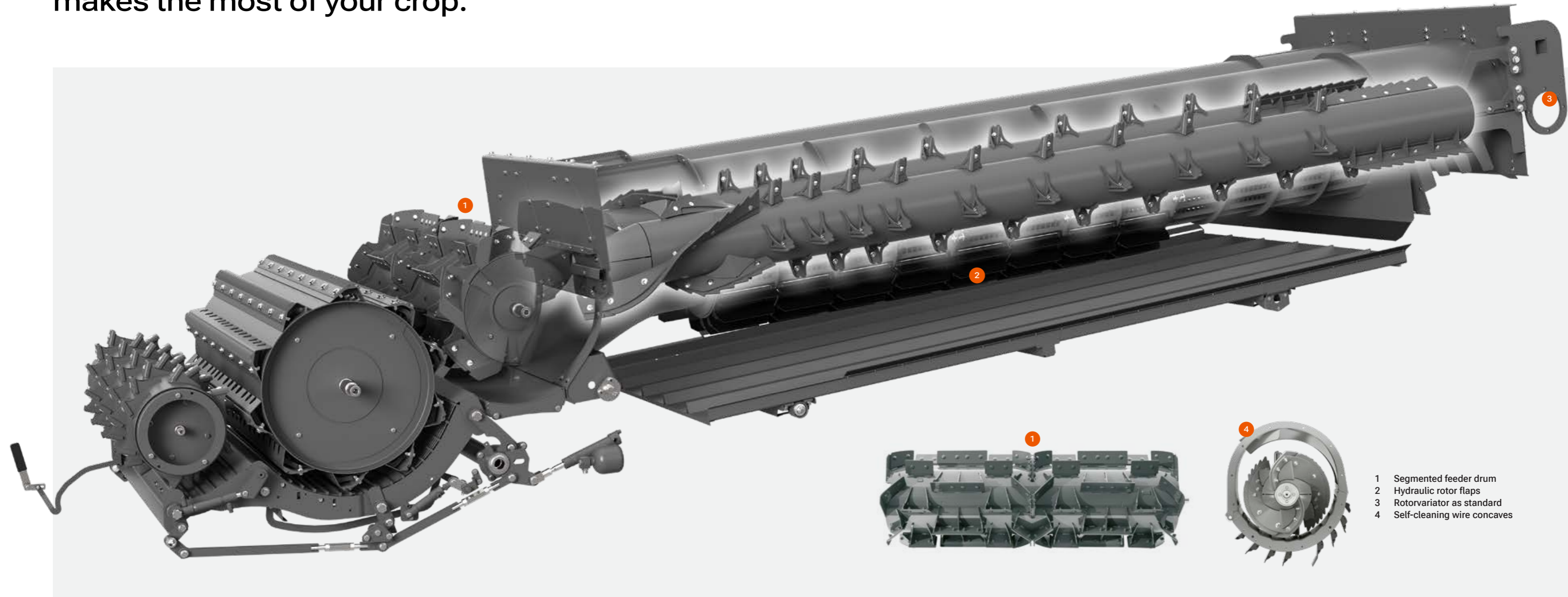

- 1 Segmented feeder drum
- 2 Hydraulic rotor flaps
- 3 Rotorvariator as standard
- 4 Self-cleaning wire concaves

## Every grain counts.

The eccentrically mounted ROTO PLUS high-performance rotors generate tremendous centrifugal force to separate the remaining grains from the straw. With a diameter of 445 mm and a length of 4,200 mm each, they provide a huge separation area.

The mixture of grain, straw and chaff first reaches the preparation floor via the separate returns pan before passing over the straw walker steps to the sieve pan. This significantly reduces the load on the sieve pan.

## New features that optimise your secondary separation:

- Six rotor concaves and a maximum rotor speed of 1,250 rpm enable outstanding separation performance.
- A 600 mm feeder drum ensures that no blockages occur as the harvested material is transferred to the rotors.
- Up to four divided hydraulic rotor flaps are fitted ex factory and prepared for incline-dependent control.
- Wear-resistant CLAAS PREMIUM LINE components make for a longer service life.

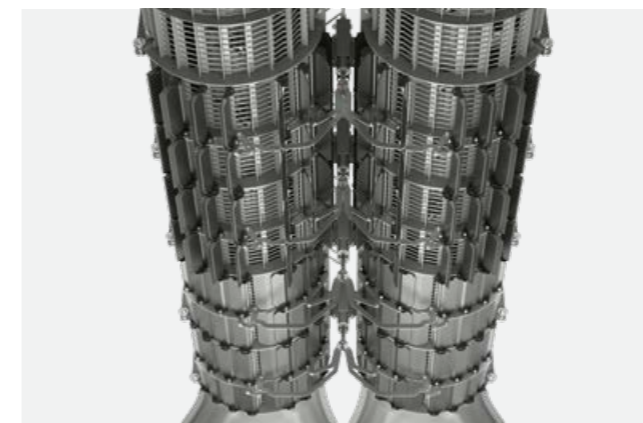

### Hydraulic rotor flap adjustment.

You can adjust the secondary separation area as required in CEBIS. Hydraulic rotor flaps close up to four rotor segments while the machine is on the move.

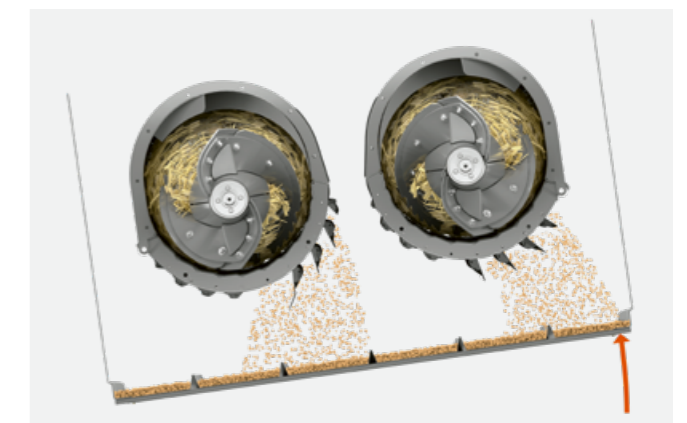

### Powerful 4D cleaning system.

The cleaning performance remains stable, even when operating in undulating terrain: the 4D cleaning system adjusts the position of the rotor flaps automatically and acts in the background to support the operator.

# You are judged on the quality of your grain.

## Intensive cleaning.

Clean grain is worth real money. The JET STREAM cleaning system with its hydraulic fan speed variator and high-performance returns is specially matched to the ROTO PLUS secondary separation. A dual-ventilated step enables intensive pre-cleaning.

JET STREAM is controlled conveniently from the cab. You no longer have to adjust anything manually. As an option, you can put the JET STREAM cleaning function under the fully automatic control of CEMOS AUTO CLEANING.



## The best way to the best grain.

- The JET STREAM cleans the grain intensively.
- The 3D cleaning system keeps the cleaning performance stable when operating on slopes.
- CLAAS PREMIUM LINE parts provide a longer service life.

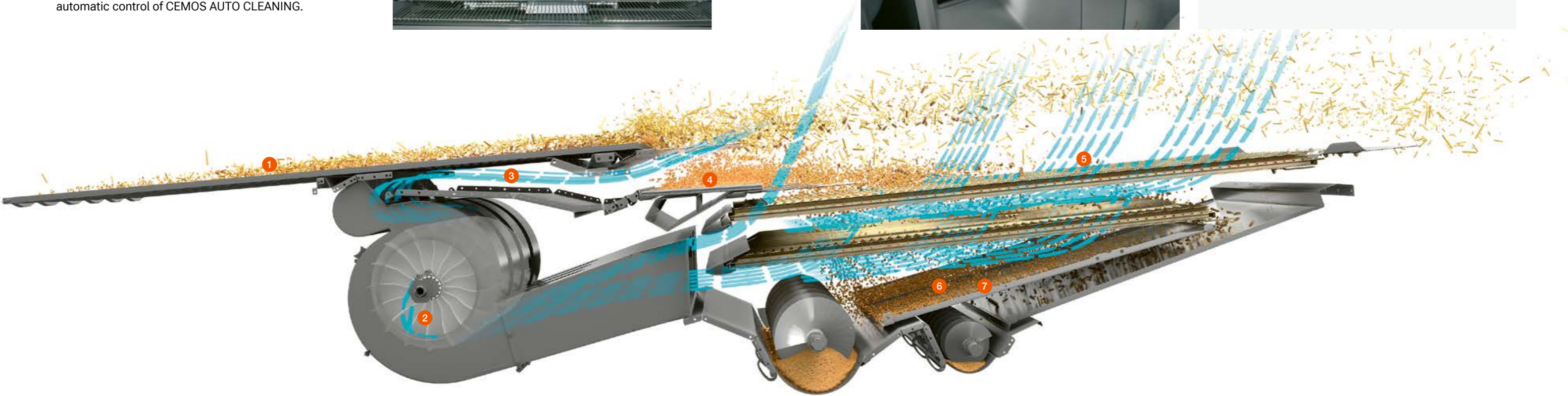

- 1 Preparation floor**  
This increases the cleaning capacity of the LEXION while also reducing the load on the upper sieve. The plastic preparation floor elements can be removed through the stone trap for easy cleaning.
- 2 Turbine fan**  
The powerful turbine fan has sufficient reserves for difficult conditions. The hydraulic variator can be controlled by CEMOS AUTO CLEANING.
- 3 Airflow equalisation duct**  
The long airflow equalisation duct with the airflow oriented upwards provides consistent cleaning performance and already achieves a high degree of separation at the first step.

- 4 Straw walker steps**  
The first step is dual ventilated and 56% higher compared with the conventional cleaning system. This enables powerful pre-cleaning with only slight sieve loading.
- 5 3D cleaning system**  
The maintenance-free system operates in the background. Using active transverse control, it distributes the material evenly across the upper sieve. This ensures that the cleaning performance remains stable when operating on slopes.
- 6 GRAINMETER**  
The GRAINMETER analyses the returns using a light barrier. This makes it possible to calculate the proportion of grains to the total volume. These data are also used by CEMOS AUTOMATIC.
- 7 Returns**  
The returns recovers every last grain from unthreshed ear sections. The material is deposited on the accelerator drum, spread out and fed to the threshing drum again.

# Measure and document constituents and yields.



## Precise identification of constituents.

The NUTRIMETER GRAIN from CLAAS is an NIR sensor that can determine the precise protein, oil and moisture content of a crop as well as mapping it and making the data available for further processing. The particularly precise transmittance measurement method developed through laboratory research enables industry-leading measurement accuracy to the standard required by the grain trade.

An ingenious bypass system integrated in the accelerator enables continuous measurement and, when necessary, easy sample collection and calibration. NUTRIMETER GRAIN opens up new possibilities for sustainable and resource-efficient cultivation and strategic marketing of quality grains and oilseed crops. The system provides precise measurements for seven crop types: wheat, barley, rye, oats, rapeseed, maize, soybeans

## You get the full picture in detail.

- Targeted separation of different quality batches on the spot in the field enables separate storage and marketing
- Precise and seamless mapping, analysis and documentation in CLAAS connect
- Make better use of the yield potential
- Use fertilisers more efficiently
- Gain a better understanding of the relationship between yield and quality



## Precise yield measurement.

The QUANTIMETER determines the yield quickly and precisely by means of a baffle plate with an integrated measuring cell at the ejection point of the grain elevator. This system can be calibrated from the cab.

## Grain tank for up to 18,000 litres and 180 l/s unloading rate.

With a volume of up to 18,000 litres, the grain tank has a capacity to match the increased throughput of the LEXION. At 180 l/s you can unload the large grain tank of the LEXION in record time. The rate can be reduced from 180 l/s to 90 l/s. If necessary, you can stop the process immediately or turn off the augers gradually in order to completely empty the grain tank unloading tube first.

- 1 QUANTIMETER
- 2 GRAIN QUALITY CAMERA
- 3 NUTRIMETER GRAIN
- 4 Sample collection

## Make perfect use of harvest logistics:

- Reliable filling of the transport vehicles
- No losses during unloading
- 4XL, 5XL and 7XL folding grain tank unloading tubes

Infrared light penetrates the grains completely without any interruption to the crop flow.

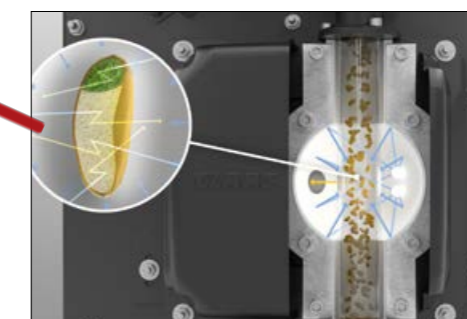

## Straw management perfectly matched to working widths up to 15 m.

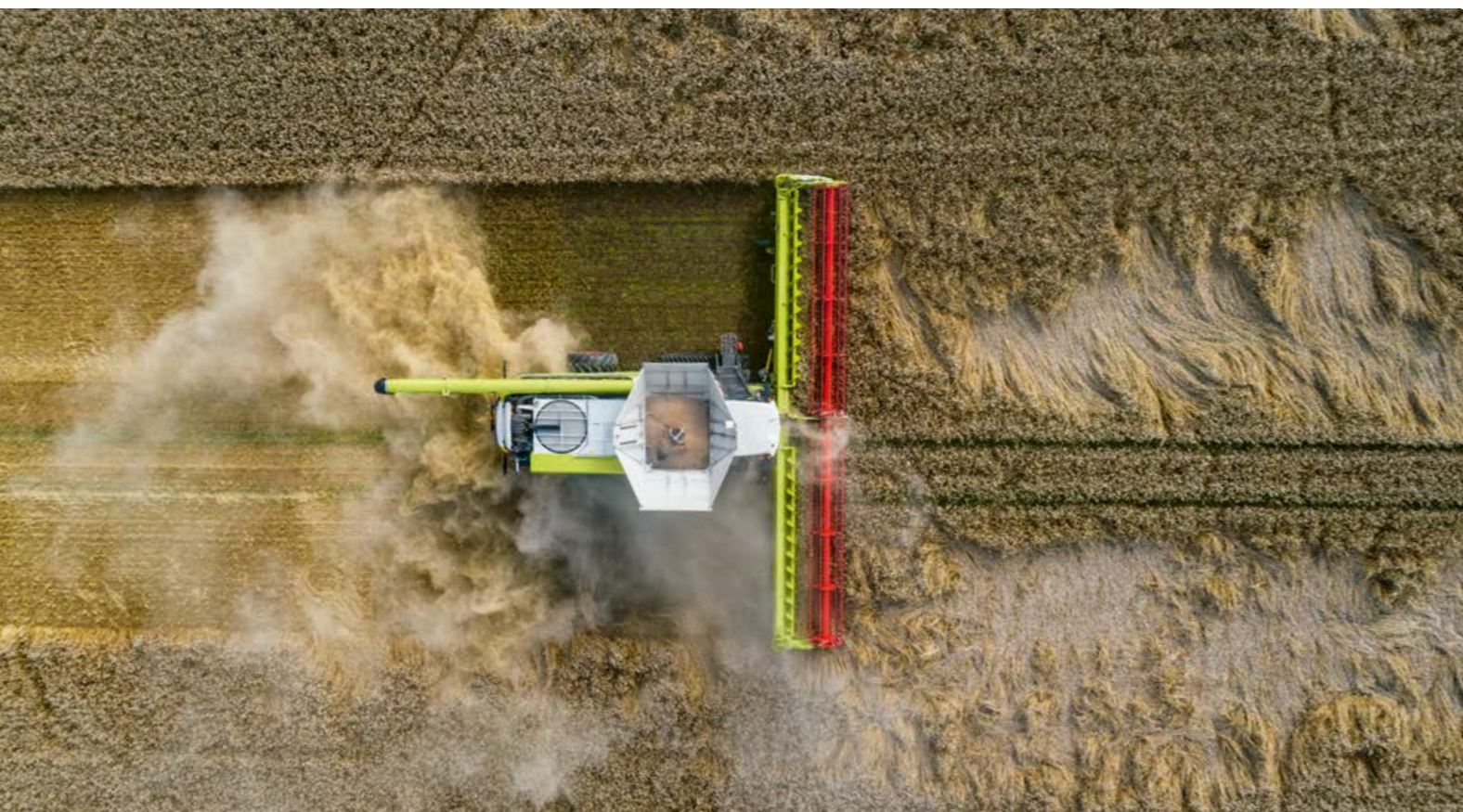

### The following crop starts here.

High straw volumes, changing levels of straw moisture, side slopes and large working widths are particular challenges during grain harvesting. High-quality chopping and precise spreading of the chopped straw provide a sound basis for subsequent tillage and cultivation.

At CLAAS, we are particularly proud of our ability to always offer you the perfect combination of combine harvester and front attachment from a single source. The expertise we apply to the front attachment interface and fully integrated automatic functions also extends to the optimal spreading of the harvest residues. The LEXION is available with an optional radial spreader with increased discharge capacity that allows it to spread straw accurately up to 15.30 metres. Combined with a CONVIO FLEX 1530, the result is a powerful harvesting asset able to deliver outstanding throughput and meet the highest performance requirements.

### CEMOS AUTO CHOPPING: intelligent straw management.

The CEMOS AUTO CHOPPING operator assistance system is an innovative straw management solution which automatically optimises the quality of the chopped material while simultaneously reducing fuel consumption. The positions of the static knife array and the friction concave plate are automatically adjusted to the current straw moisture level in order to ensure consistently optimal results.

#### Your benefits at a glance.

- High-quality chopped material produced efficiently: automatic adjustment of the system ensures consistently high-quality output
- Reduced fuel consumption: the intelligent automatic mode uses resources sparingly and helps to keep operating costs down



### Technology that makes your straw management efficient:

- Mechanically driven radial spreader for precise straw deposition up to a working width of 15m
- Up to 108 chopper knives
- Switchover to swathing performed from the cab
- CEMOS AUTO CHOPPING for optimal chopped material quality and lower fuel consumption

### Discharge direction is optimised automatically.

You can equip your LEXION with two sensors which automatically adjust the discharge direction of the chopped material to the terrain conditions. The sensors are fitted on the light brackets at the rear of the machine and ensure that the radial spreader and deflector spread the chopped material evenly on slopes or in the event of crosswind.

### Targeted chaff spreading.

During swathing, the chaff blower automatically turns outwards. Swaths of long straw and chaff/broken straw mixture are laid and spread separately. For straw spreading, however, the chaff blower forces the sieve pan discharge straight into the radial spreader for active distribution. The chopped straw and the sieve pan discharge are spread across the entire working width.

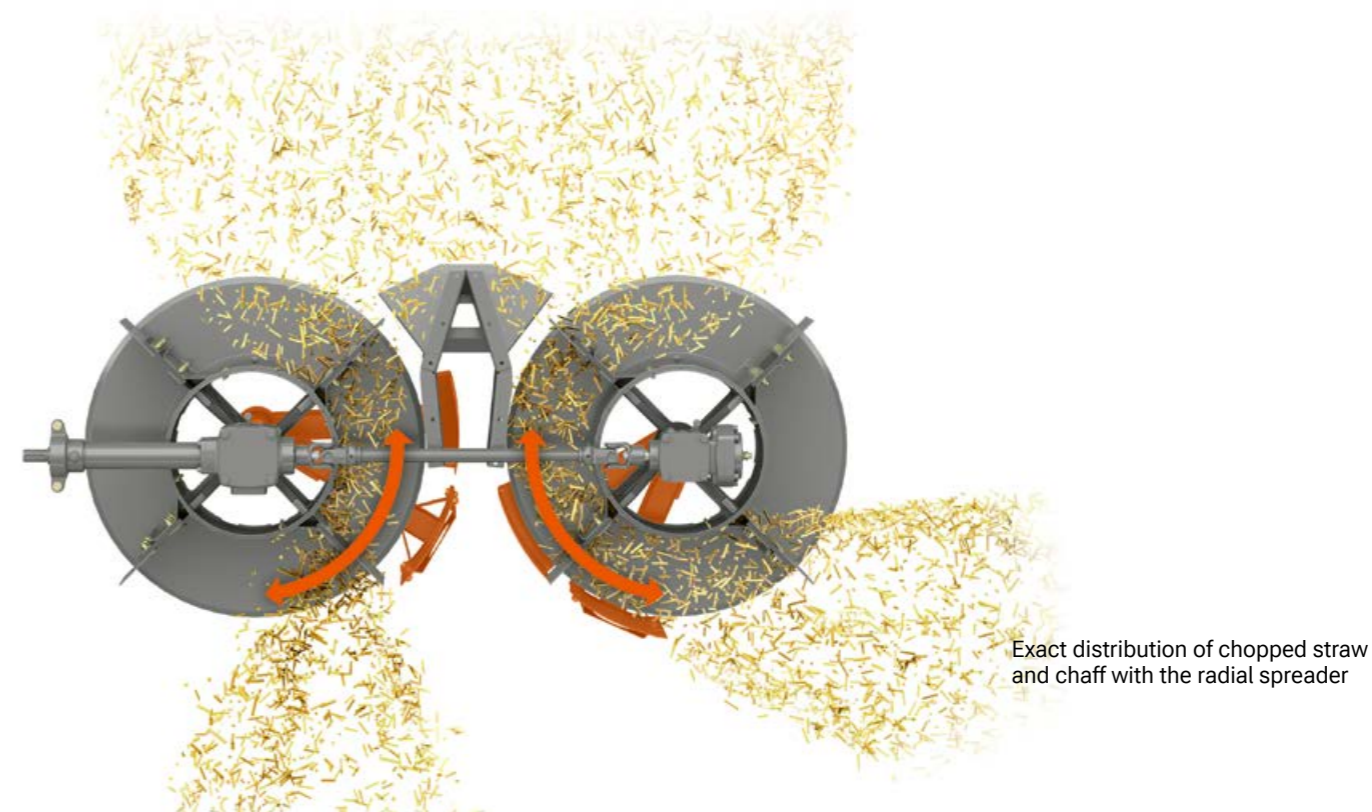

Exact distribution of chopped straw and chaff with the radial spreader

# Campaign performance needs power. CLAAS Power Systems.

## Interplay of optimal components.

Top performance happens when all the parts of your CLAAS machine are precisely matched to each other and work together optimally. CLAAS POWER SYSTEMS brings together the best components to form an intelligent drive system: drives which are suited to your requirements and the way you use your machines; full engine output only when you require it; fuel-saving technology which quickly pays off.

## Don't accept any compromises.

You have many possibilities for optimising the LEXION to meet the characteristics of your farm and your fields so precisely that your campaign performance increases to a significant degree.

- You benefit from higher engine output.  
The LEXION 8700 can now call on 646 hp instead of 625 hp, the LEXION 8600 has an output of 598 hp instead of 549 hp
- The LEXION 8700 and 8600 are driven by powerful MAN engines with a displacement of 15.6 litres.
- DYNAMIC POWER adjusts the engine output to the power requirement. This allows you to achieve fuel savings of up to 10%.
- DYNAMIC COOLING reduces your diesel costs. The variable fan drive adjusts its speed automatically in line with the degree of cooling required.
- TERRA TRAC reduces soil compaction. The crawler track units offer a high level of driving comfort and are narrow enough for road travel.

**CPS** | CLAAS  
POWER  
SYSTEMS



# DYNAMIC POWER - the intelligent way to put power down.

## More intelligence for the engine.

DYNAMIC POWER automatically adjusts the engine output of your LEXION to the operating conditions. This means that you are always running with the most efficient power curve when operating under partial load and can achieve fuel savings – during swathing, for example – of up to 10%. At full load when the grain tank is being unloaded and the straw chopper is engaged, for example, maximum engine output is automatically maintained.



DYNAMIC POWER adjusts the engine output to the current power requirement.

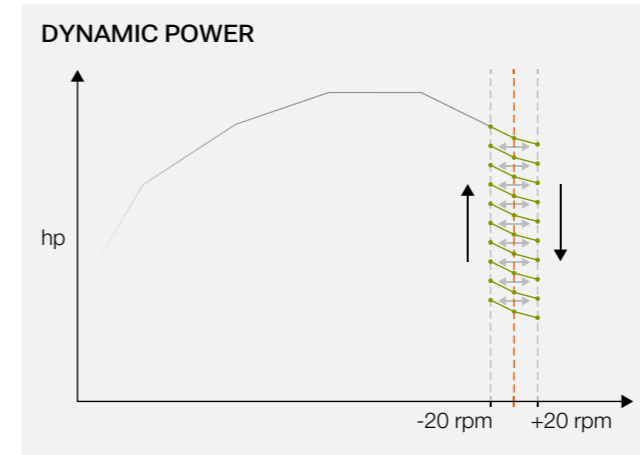

## Intelligent power.

DYNAMIC POWER uses a variety of power curves on the basis of the engine load. The parameter which triggers the power adjustment is the reduction or increase in the engine speed resulting from a change in the power requirement.



## Lower revs on the road.

On the road, the LEXION makes do with just 1,600 rpm. This technology makes it possible for you to save significantly more fuel while running at a reduced noise level and with a high level of driving comfort.



## Technology that helps you save fuel:

- The LEXION 8800 can call on 700 hp while the LEXION 8700 has an output of 646 hp.
- DYNAMIC POWER adjusts the engine output to the current power requirement.
- You are always operating with the most efficient performance curve in the partial load range.
- Fuel savings of up to 10% are possible during swathing.
- The engine speed is reduced to 1,600 rpm during road travel.
- This significantly reduces the noise level and diesel consumption.

# DYNAMIC COOLING - the smart solution.



## Intelligence saves diesel.

Based on a variable fan drive which is unique in the combine harvester sector, DYNAMIC COOLING adjusts its speed automatically and, above all, in accordance with the degree of cooling required.

Whatever the outside temperature, DYNAMIC COOLING is able to cope easily. The system not only delivers reliable cooling, but also uses a curtain-effect air flow to reduce the extent to which dust is able to rise. DYNAMIC COOLING requires 20 kW less engine output, thereby helping you to save fuel.

## What makes DYNAMIC COOLING so unique?

- Variable fan drive provides cooling when required
- Provides effective and reliable cooling
- Uses full fan speed only under full load
- Minimises extent to which dust is able to rise
- Reduces soiling of the radiator and engine compartment
- With grain tank unloading tube extended, automatically increases speed to actively blow dust away from engine compartment
- Extends the air filter maintenance intervals

## Cooling and cleaning in one.

Drawn in vertically at the top, the fresh air passes through a rotating sieve with a diameter of 1.60 m. It is then vented through the engine compartment and over side cooling fins. This ideal air flow prevents almost all dust from rising and so effectively functions as a permanent cleaning system.

Large cooling package for sufficient reserves of cooling capacity.

- 1 Radiator
- 2 Oil cooler
- 3 Intercooler
- 4 Condenser
- 5 Fuel cooler



## Your time is too valuable to waste.

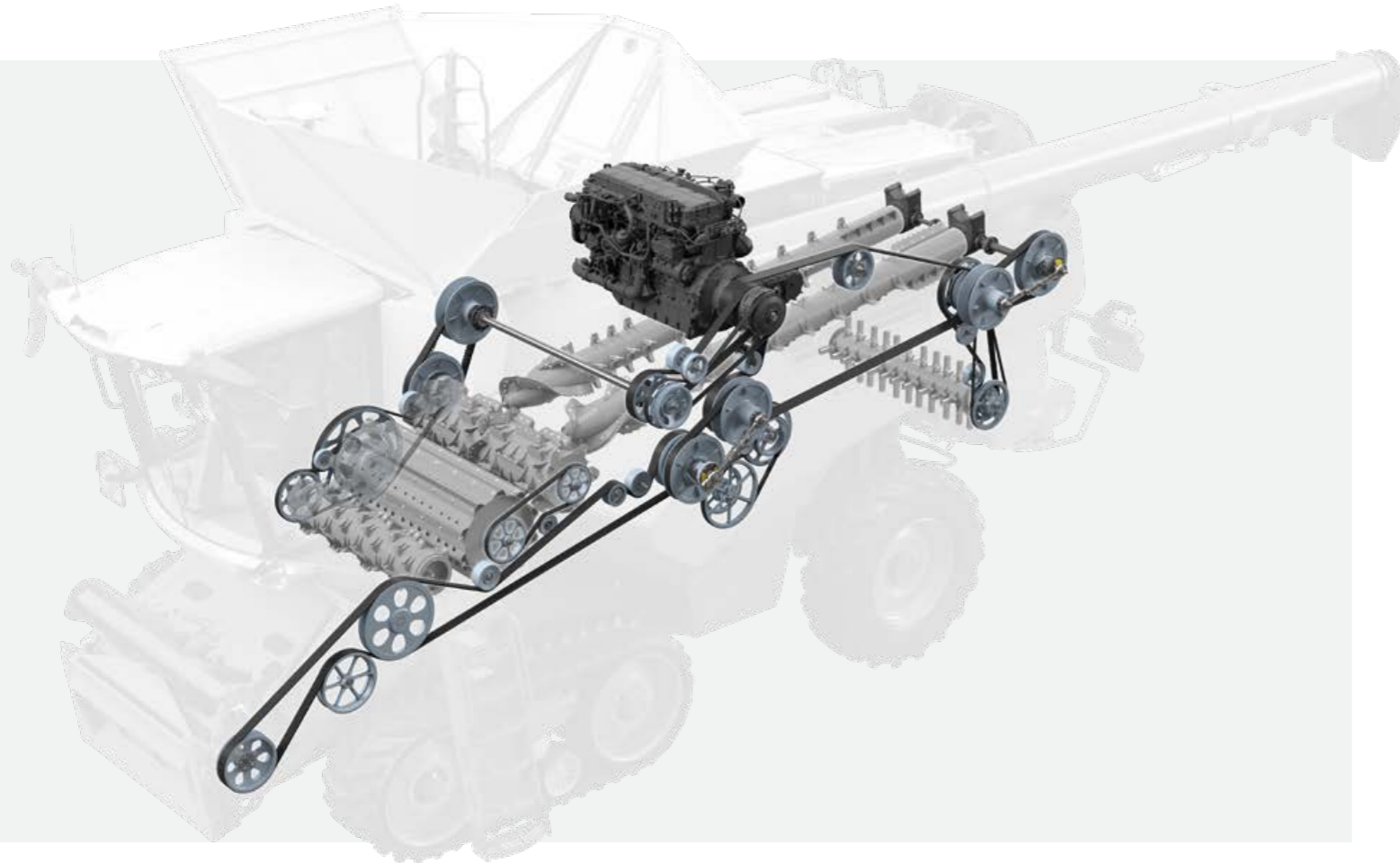

### Hydrostatic ground drive up to 40 km/h.

All LEXION models are equipped with a 2-speed hydrostatic ground drive with convenient gear selection via the buttons on the armrest. The high efficiency of the hydrostatic motor saves power which is available to the rest of the machine. Both the wheeled machines and the TERRA TRAC models can travel at up to 40 km/h.

### Automatic parking brake for your safety.

If you run for more than one second at less than 1 km/h, change gear, switch the engine off or get out of the seat, the LEXION automatically activates the parking brake. This increases both your driving comfort and your safety when you leave the cab. The brake is released again as soon as you operate the ground speed control lever.

**40**

40 km/h top speed for all wheeled machines and TERRA TRAC models

### A drive system that has what it takes:

- Hydraulically actuated dry clutch
- Hydraulically tensioned main belts
- Standardised belt tensioners
- Improved power transmission
- Lower maintenance costs

### Differential lock for improved traction.

The electrohydraulically operated differential lock, which is activated simply by means of a pushbutton in the centre console, ensures that you can continue to operate safely and reliably in extreme conditions. The high traction and pulling power of the LEXION are maintained on slopes and in the wet. You can also engage the differential lock under load.

### Automatic function for more comfort.

The differential lock automatic engagement and disengagement function makes working with the LEXION particularly comfortable and safe.

- Automatic engagement when ground speed is less than 10 km/h, steering angle less than 15° or slip occurs
- Automatic disengagement when ground speed is over 10 km/h, steering angle over 15° or braking occurs



### Tyres for high level of soil protection.

Tyre diameters of up to 2.15 m for the front wheels and 1.71 m for the rear help you protect the soil while working.

### Powerful POWER TRAC 4-wheel drive.

When ground conditions are difficult, a push of a button is all it takes to engage the 4-wheel drive in order to benefit from greater traction. Or you can use the standby mode, in which the 4-wheel drive is permanently available in the background and can be activated quickly if required.

- **ON:** rear wheels are mechanically engaged and are driven
- **STANDBY:** rear wheels are mechanically engaged but are not driven
- **OFF:** rear wheels are mechanically disengaged

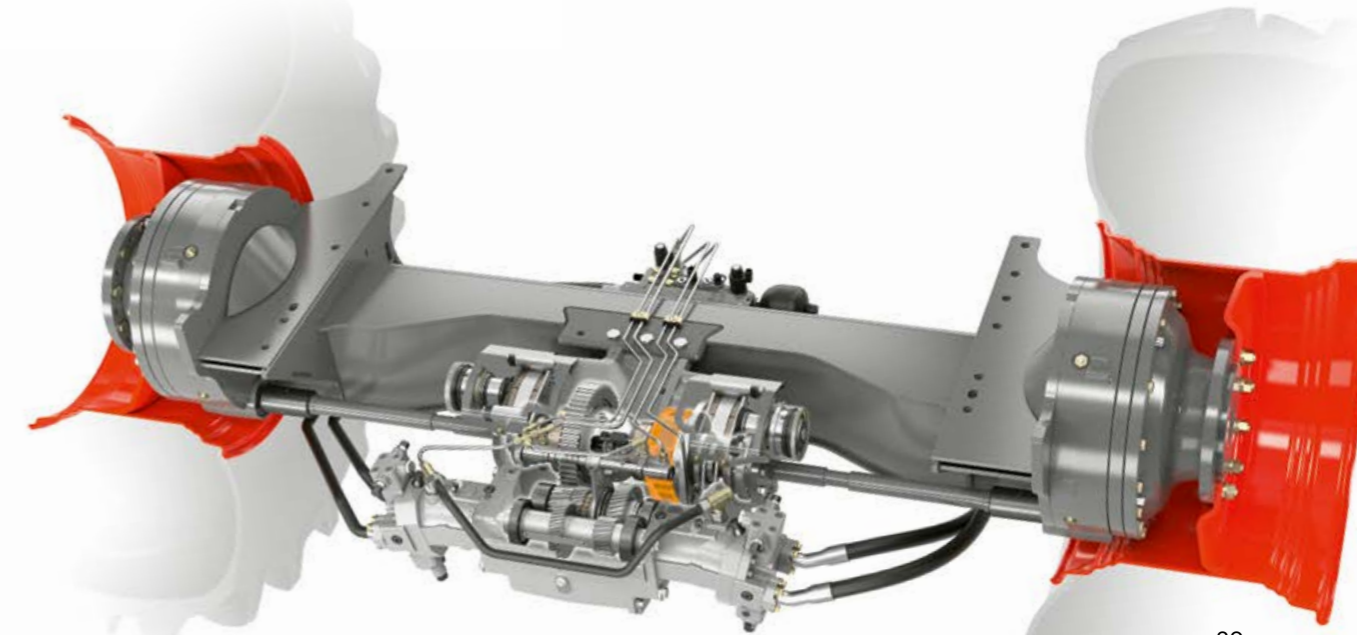

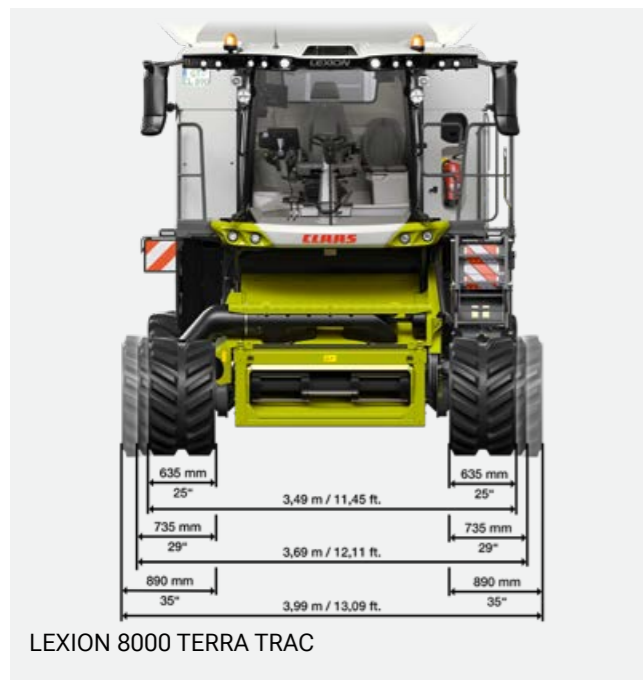

TERRA TRAC for every requirement.



### Third-generation crawler unit.

The soil is the most important basis for production available to you. As it is impossible to create more of it, you need to be able to obtain ever greater yields from the existing land. The key to this is more productive machines which, thanks to TERRA TRAC, are extremely gentle on the soil.

The third generation of TERRA TRAC crawler tracks impresses with the large diameter of the land wheels, hydro-pneumatic suspension, improved track tensioning and automatic level compensation from 2 km/h. The TERRA TRAC system increases traction drastically and leaves hardly any trail behind it when operating in the wet, on soft ground or on side slopes. This makes the work of the transport vehicles considerably easier.

### TERRA TRAC on the road.

- 40 km/h top speed possible
- Fully suited to road travel at 20, 25, 30 and 40 km/h
- High driving safety and directional stability
- More driving comfort compared with a wheeled machine

### TERRA TRAC in the field.

- Up to 66% less ground pressure than wheeled machines
- Better traction in maize, in the wet and on slopes
- Less slip and greater stability on side slopes
- Lower drive resistance and fuel consumption

### TERRA TRAC in rice.

- Special rice track, 890 mm wide
- Greater spacing of tread lugs for self-cleaning
- High traction and load-bearing capacity
- Will not sink in when operating in wet field conditions

## A comfortable working environment also helps to increase output.

### Working days are getting longer.

Achieving high campaign performance means being aboard your machine from morning to evening. It is therefore clear that you need all the support you can get. This is another area in which the LEXION has more to offer than ever before: from self-learning operator assistance systems to high end lighting packages that keep the area which you are working as bright as day.

### Comfort improves performance.

We know that you are more productive in the field when you have a comfortable working environment. This is why the cab of the LEXION is designed for comfort. As well as being distinctly spacious at head, shoulder and leg level, it features an intelligent control system and a bright CEBIS terminal which provides a razor-sharp display of all the information you need.

- Whether the day is hot or cold, you will be in your comfort zone. The optimised airflow ensures a pleasant temperature in the cab.
- You will also be comfortable throughout the longest of working days, whether you choose the standard seat or the premium leather seat.
- Everything is safely stowed and kept pleasantly cool in the storage compartments in the B-pillar or the cool box under the instructor's seat.
- Stay informed and well organised with the digital radio with hands-free facility and the tablet holder.
- You can keep working when night falls thanks to the LED work lights and the maintenance lighting available in a number of different versions and configurations.
- Camera systems give you a clear view for added safety and convenience when performing tasks such as unloading the grain tank or hitching up the cutterbar trailer.
- The radio sound system with Apple Car Play und Android Auto delivers the best in in-cab entertainment.



# The focus is on the operator.

## Higher comfort. Higher performance.

When your job calls for you to deliver top performance, day after day, you deserve a working environment where you feel at ease. Ergonomic seats and well thought-out air conditioning keep you free of stress, even on long harvesting days. A high-quality sound system, practical storage compartments and an integrated cool box make every minute at work more pleasant.

- 1 CEBIS control terminal
- 2 Armrest with direct adjustment
- 3 Plenty of storage
- 4 Refrigerator box
- 5 Very quiet cab for pleasant working days



## A cab full of highlights.

- New radio system with 6.75-inch display for Apple Car Play® & Android® Auto
- Low noise level through efficient cab insulation and reduced engine speed
- Comfortable seats for long working days
- Plenty of space in the storage compartments and the cool box
- Mobile phone holder with wireless charging function
- LED work lights and maintenance lighting
- Camera systems for a complete overview
- Compressed air connection with spiral hose and air pressure gun in the cab for practical cleaning on the go

You have a choice of two comfort packages to meet your specific requirements:

### Operator Package PLUS

- Comfort seat, air-suspended
- Leather-upholstered armrest and leather steering wheel
- Radio sound system with hands-free facility
- Storage compartments with USB-C port in the B-pillar
- Footrests
- Instructor's seat with cool box
- Various radio options
- Mobile phone holder with wireless charging function
- Roller sun blinds for the side windows

### Operator Package PROFESSIONAL

- Air-suspended premium leather seat, swivelling
- Radio sound system with Apple CarPlay®, Android® Auto and touchscreen

For optimum visibility and maximum safety.

### Light & Visibility Package PLUS

- LED Plus work lights
- Windscreen wiper system
- Close-proximity mirror
- Electrically adjustable and heated rear-view mirrors
- Rear camera with display on CEBIS terminal

### Light & Visibility Package PROFESSIONAL

- LED Professional work lighting
- Wiper system for windscreen and side windows
- Additional camera options and additional display screen for camera image



Apple CarPlay and Android Auto provide the right soundtrack for your harvest



For quick cleaning on the go – the air pressure gun in the cab

# A LEXION is easy to drive.

## CEBIS operates intuitively.

Operation is intuitive and possible without previous knowledge. This means that even new operators are able to use the LEXION in a short time. CEBIS plays a decisive role in this. The system is an information supplier, performance optimiser and problem solver all rolled into one.

## CEBIS offers immediate assistance.

Stored in CEBIS is a library of measures – based on the experience of countless CLAAS combine harvester operators – for resolving various problem scenarios. They consider all the parameters which could contribute to solving the problem. This comprehensive resource supports you in making full use of the installed capacity of the machine.

## CEBIS simplifies the menu.

Beginner, normal or expert: you define your user type and CEBIS adjusts the menu system to your level of experience. This ensures that new operators are not overwhelmed by complex menus. The operator assistance system is also integrated in CEBIS. You operate CEMOS DIALOG and CEMOS AUTOMATIC via the user-friendly touchscreen. Using the four sliders, you program the system's automatic functions with the strategies you wish them to follow.



### 1 CEBIS touchscreen

CEBIS responds immediately to a tap on the touchscreen. You have direct access to the field work and road travel machine functions as well as to all the operator assistance modules, such as CEMOS AUTOMATIC.

### 2 CEBIS rotary push switch

Even when operating in bumpy terrain in the field, you can easily navigate the CEBIS control panel using rotary/push switches and the Escape and Favourites buttons – to adjust the threshing drum speed, for example.

### 3 Direct adjustment via switches

You operate predefined basic functions directly by means of assigned switches. In this way, you can adjust the sieve opening or the fan speed, for example.

### 4 CMOTION favourites management

Seven settings can be programmed as favourites in CEBIS. When working, you can call these up conveniently via rocker switches on the CMOTION ground speed control lever. Your hand intuitively actuates the relevant switches while you keep a close eye on the front attachment.



CEMOS DIALOG integrated in CEBIS

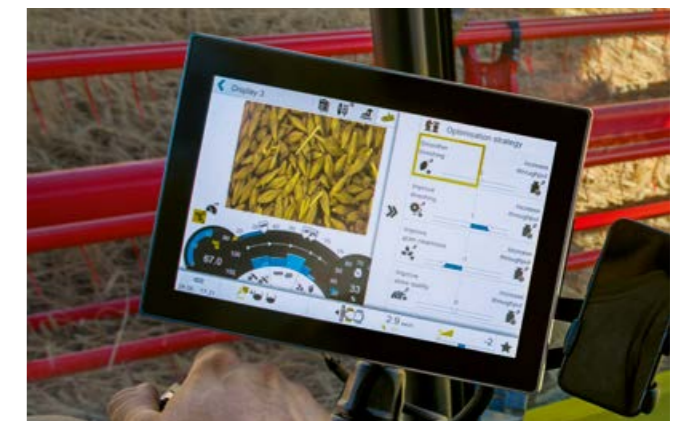

Intelligent control by CEMOS AUTOMATIC via CEBIS

## User-friendly design that supports the operator and reduces stress.

- Depending on your preference, settings can be adjusted in three ways in the LEXION: via the CEBIS touchscreen, the CEBIS rotary push switch or the direct-adjustment switches.
- Operating the direct adjustment system causes a dialogue box to open in CEBIS.
- A numeric keypad helps you enter precise target values.
- All parameters can be modified easily by means of dial and slide controllers in CEBIS.
- All the functions of the CEMOS AUTOMATIC operator assistance system, as well as CEMOS DIALOG, are integrated in CEBIS.
- You can call up your seven favourites directly on the CMOTION ground speed control lever.

# Every harvest benefits from these systems.

## Digitalisation is indispensable.

We have three very good reasons for digitalising our machines: we want to help your operators work more confidently, to make your harvest go more smoothly and to reduce your costs. With self-learning operator assistance systems such as CEMOS AUTOMATIC, for example, or steering systems that are accurate down to the last centimetre.

## Connected machines are more productive.

To enable you to get more out of your CLAAS machines, we have a range of modules to connect them with the farm. The line-up extends from yield mapping to fleet coordination to continuous documentation of your job and yield data.

- Let CEMOS AUTOMATIC reduce your workload significantly. Select the appropriate modules from entry level to the full version.
- CEMOS AUTO HEADER actively controls the position of the reel and the VARIO cutterbar table.
- The more precise your movements in the field, the more efficiently you will be able to harvest. Accurate down to as little as 2.5 cm, the GPS PILOT CEMIS 1200 keeps the number of passes required to a minimum.
- Collect and process your data how and where it suits you. CLAAS connect gives you a whole host of options.
- Increase throughput, grain quality and comfort. Active forward travel control or a threshing unit which adjusts itself help you achieve these goals.



# CEMOS operators are unbeatable.

## Configure CEMOS AUTOMATIC for your specific requirements.

CEMOS AUTOMATIC is a self-learning operator assistance system which provides you and your operators with continuous, active support throughout the entire work process. On the basis of harvesting parameters, such as grain quality, threshing quality, standard of cleaning, straw quality and throughput, the system checks sensors and settings. It optimises your LEXION to its technical performance limits while it is running.

### The operator decides.

You tell the system your requirements concerning the grain quality and loss level. During harvesting, CEMOS AUTOMATIC optimises the performance of your machine to meet your criteria precisely.

## Performance made to measure: CEMOS packages. There's a level to meet every requirement.

**CEMOS AUTO**  
10% performance increase with greater comfort, safety and learning capability

- Automatic forward travel control
- Dialogue-based optimisation
- Consistent threshing quality
- Automatic crop flow monitoring
- Lasting learning effect
- Operator stress relief and operating safety are increased

**CEMOS AUTO Plus**  
up to 20% performance increase and improved grain cleaning

- Automatic optimisation of ROTO PLUS secondary separation and cleaning
- Digital measurement and display of composition of returns
- Lasting learning effect
- Operator stress relief and operating safety are increased

**CEMOS AUTO Professional**  
automatic optimisation along the entire crop flow path

- Automatic optimisation of the threshing unit
- GRAIN QUALITY CAMERA captures and analyses grain quality and cleaning
- Fewer impurities
- Optimisation of grain quality
- Lasting learning effect
- Operator stress relief and operating safety are increased

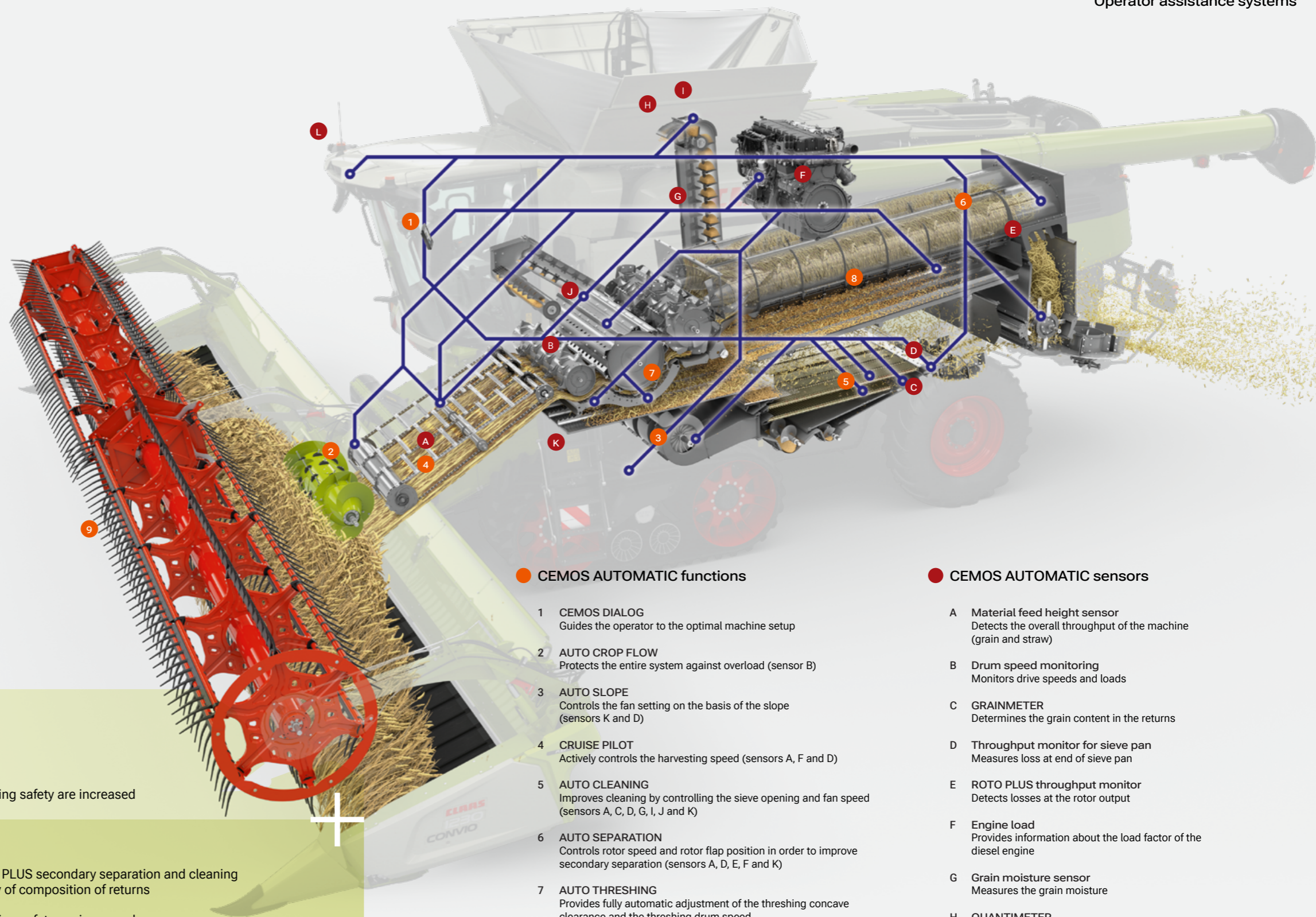

### CEMOS AUTOMATIC functions

- CEMOS DIALOG**  
Guides the operator to the optimal machine setup
- AUTO CROP FLOW**  
Protects the entire system against overload (sensor B)
- AUTO SLOPE**  
Controls the fan setting on the basis of the slope (sensors K and D)
- CRUISE PILOT**  
Actively controls the harvesting speed (sensors A, F and D)
- AUTO CLEANING**  
Improves cleaning by controlling the sieve opening and fan speed (sensors A, C, D, G, I, J and K)
- AUTO SEPARATION**  
Controls rotor speed and rotor flap position in order to improve secondary separation (sensors A, D, E, F and K)
- AUTO THRESHING**  
Provides fully automatic adjustment of the threshing concave clearance and the threshing drum speed (sensors A, B, D, E, F, G, H and I)
- 4D cleaning system**  
Controls the rotor flap position on the basis of the slope in order to make optimal use of the cleaning capacity (sensors K, D and E)
- NEW: AUTO HEADER**  
Actively controls the position of the reel and the VARIO cutterbar table (sensors A and L)

### CEMOS AUTOMATIC sensors

- A Material feed height sensor**  
Detects the overall throughput of the machine (grain and straw)
- B Drum speed monitoring**  
Monitors drive speeds and loads
- C GRAINMETER**  
Determines the grain content in the returns
- D Throughput monitor for sieve pan**  
Measures loss at end of sieve pan
- E ROTO PLUS throughput monitor**  
Detects losses at the rotor output
- F Engine load**  
Provides information about the load factor of the diesel engine
- G Grain moisture sensor**  
Measures the grain moisture
- H QUANTIMETER**  
Determines the machine's grain throughput
- I GRAIN QUALITY CAMERA**  
Determines the grain quality
- J Returns volume**  
Detects the overall volume in the returns
- K Incline sensor**  
Measures the machine incline
- L FIELD SCANNER**  
Detects the height of the plants

# Optimise CEMOS AUTOMATIC for your harvest.

## The functions of CEMOS AUTOMATIC.

In CEMOS AUTOMATIC you have a self-learning, modular operator assistance system. Choose from the set of available functions the ones that are most cost-effective for your farm.

CRUISE PILOT and AUTO SLOPE, for example, provide economical access to automation. With these functions, as well as benefiting from intelligent forward travel control, your LEXION is able to adjust the fan speed automatically.

Or you can choose the full version of CEMOS AUTOMATIC and let the machine optimise its threshing unit, primary and secondary separation autonomously. You benefit from high throughput, clean grain and reduced fuel consumption.

## Harvesting at the limit.

- You obtain more throughput and a high standard of grain cleaning.
- Downtime due to blockages or overloading is avoided.
- The fuel efficiency of your LEXION is improved.
- You have no outages because of incorrect settings.
- You reduce costs and effort effectively.
- You increase your campaign performance.
- Your operators' workload is reduced significantly.

## AUTO CROP FLOW recognises peak loads.

If the preset slip limit is overshot, AUTO CROP FLOW prevents any more material from entering the machine. This avoids downtime due to blockages, damage or overloading.

## AUTO SLOPE manages cleaning on slopes.

AUTO SLOPE reduces your workload by controlling the fan speed on the basis of the longitudinal tilt.

- You increase throughput and reduce grain losses on slopes.
- The cleaning performance always remains stable.

## CRUISE PILOT controls the speed.

The optimal harvesting speed increases your productivity. CRUISE PILOT controls it automatically. It is possible to choose from three strategies:

- 1 Maximum throughput with loss monitoring: you are always harvesting at the machine's performance limit.
- 2 Constant throughput: all the key assemblies are subject to consistent loading even under changing conditions.
- 3 Cruise control: you work at a constant harvesting speed.

## CEMOS AUTO CHOPPING.

The positions of the static knife and the friction concave plate are automatically adjusted to the current condition of the straw in order to improve the quality of the chopped material.

## CEMOS AUTO CLEANING.

The fan speed and the upper and lower sieve opening are the parameters by which CEMOS AUTO CLEANING automatically regulates the cleaning. In the background, the system continuously tests various settings to optimise performance. If parameters such as yield, grain quality, throughput or moisture change, CEMOS AUTO CLEANING reacts immediately.

## CEMOS AUTO SEPARATION.

The LEXION uses CEMOS AUTO SEPARATION to optimise the secondary separation continuously. It automatically adjusts the speed of the rotors and the position of the rotor flaps as soon as the harvest conditions change.

## CEMOS AUTO THRESHING.

The system improves the performance of the threshing unit and primary separation. It controls the threshing concave clearance and the threshing drum speed fully automatically. A comparison of all the possible settings to optimise performance takes place in the background. The data on which this is based are supplied by numerous sensors in the machine.

## CEMOS AUTO HEADER.

The FIELD SCANNER sensor detects the height of the plants while the material feed height sensor in the feeder housing evaluates the crop flow. On the basis of these data, CEMOS AUTO HEADER actively controls the position of the reel and the VARIO cutterbar table. This results in an optimal crop feed at all times along with a significant reduction in the workload for the operator. CEMOS AUTO HEADER is available for VARIO and CONVIO cutterbars.

CEMOS AUTOMATIC supports your harvesting performance.

- AUTO THRESHING
- AUTO SEPARATION
- AUTO CLEANING
- CRUISE PILOT
- AUTO CROP FLOW
- CEMOS DIALOG

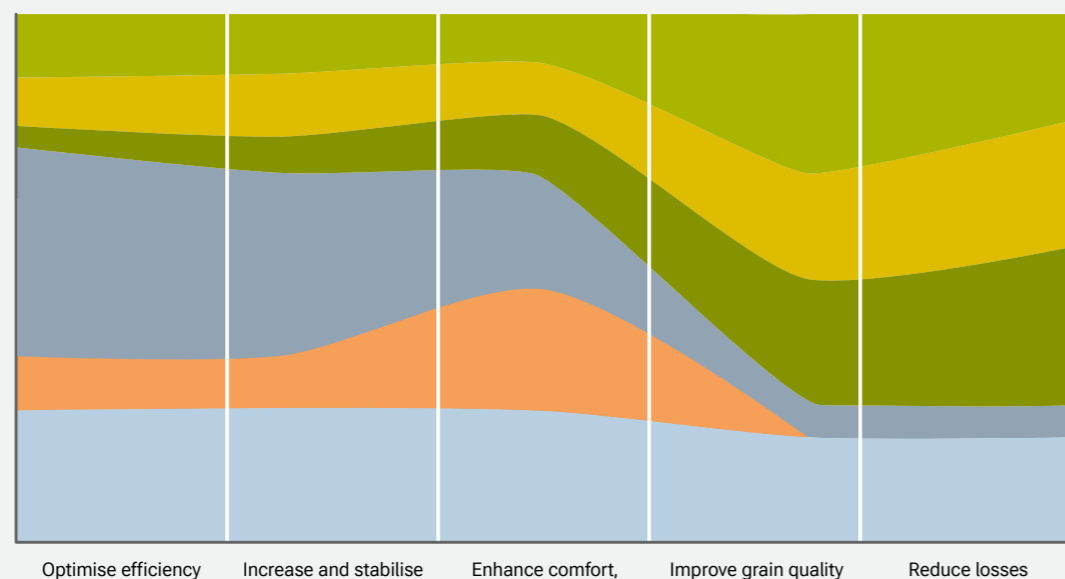

How the CEMOS AUTOMATIC functions benefit the customer

The CEMOS AUTOMATIC functions support you throughout the entire harvest. You can configure the functions in such a way that they are a precise fit for your requirements. The user-friendly CRUISE PILOT, for example, helps you optimise efficiency while increasing throughput and stabilising it. If you wish to improve the grain quality and reduce losses, AUTO THRESHING will provide you with optimal support.



CEMOS AUTO HEADER has been awarded a silver medal by the Agritechnica Innovations Commission.

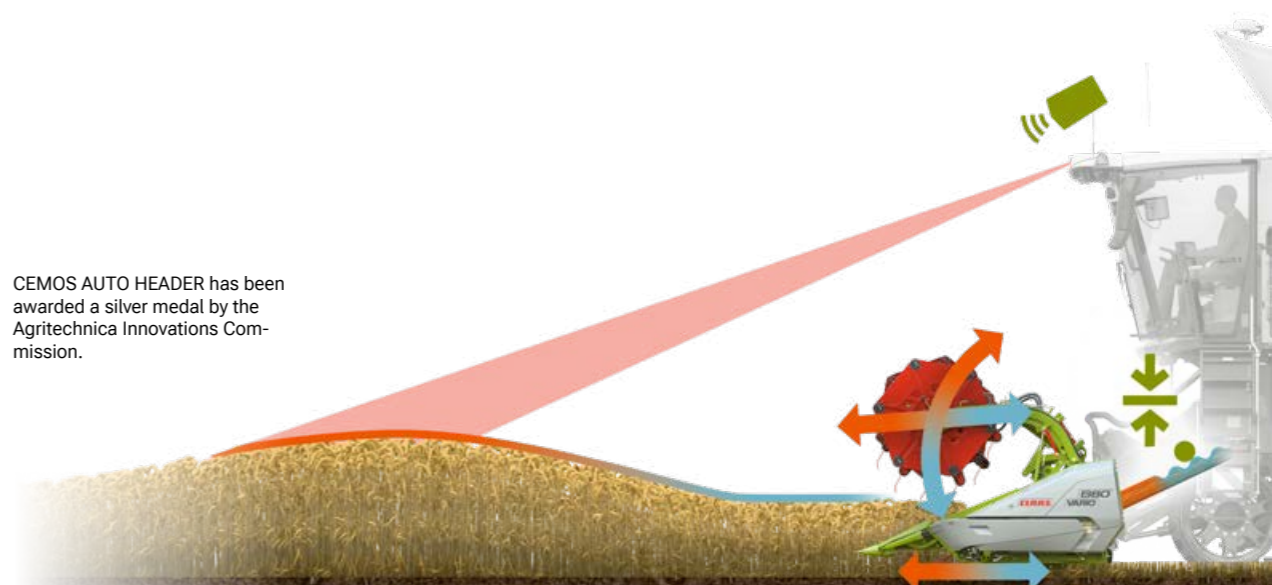

# CEMOS DIALOG motivates you like never before.



## Greater safety and reliability in the field.

Controlled through CEBIS, the CEMOS DIALOG operator assistance system guides you to the optimal machine setup. Settings which are confirmed by you are implemented directly by CEMOS DIALOG. You are motivated to check the settings more frequently and also benefit from the learning effects.

## NEW: CEMOS DIALOG analyses the machine's performance.

The machine always keeps you informed about the scope for optimisation. It continuously indicates all the factors imposing the greatest limitations on throughput and actively suggests ways to increase performance.

It even calibrates the sensitivity of the loss sensors automatically while running. If you change the accepted loss level during harvesting, CEMOS DIALOG automatically adjusts the sensitivity of the sensors. There is no need for another loss measurement to be performed.

## CEMOS Advisor app supports you.

The free CEMOS Advisor smartphone app helps you find the optimal machine setting. The grain loss calculation is already integrated in this valuable adjustment aid.

## Harvest right up to the grain loss limit.

- You only have to calibrate the loss sensors at the start of the day.
- CEMOS DIALOG actively supports you with loss measurements.
- After the loss level has been changed, the sensitivity of the sensors is corrected automatically.
- The machine always works precisely up to the limit set for acceptable losses.



## Determine losses.

### Increase campaign performance.

Setting the correct loss rate plays a decisive role in increasing your campaign performance. An accurately set grain loss ratio ensures that you do not waste any power. Once the losses have been determined and the sensitivity of the loss sensors has been adjusted accordingly, CEMOS AUTOMATIC applies the optimal settings. In this way, the system always brings the machine precisely up to the limit of acceptable losses. Another benefit of this system is that it prevents the entry of incorrect values which could slow the machine down.

### Loss sensor programming.

CEMOS DIALOG supports you when it comes to calibrating the loss sensors for the separation and cleaning stages. You can use the same loss control pan which you are already using.

The system guides you steadily, step-by-step, through the loss measurements. It asks you to input the dimensions of your loss control pan and tells you when to deploy it. Once you have entered the measurements obtained with the loss control pan (volume, weight or number of grains), CEMOS DIALOG suggests a value for the sensitivity of the loss sensors. The better the sensor sensitivity setting, the more precise the loss indication.



The dimensions of the loss control pan being used are entered in CEBIS

### Adjusting the sensitivity.

This is a situation you will recognise: you start harvesting in the morning with a loss level of 0.5%. In the afternoon, there is a risk of rain. You want to adjust the loss limit to 1%. As soon as you enter the new loss value, CEMOS DIALOG automatically determines the corresponding value for the sensitivity of the loss sensors. CEMOS AUTOMATIC runs the machine at the maximum loss limit again and optimises the throughput. This saves you a lot of time, as there is no need for another measurement of losses to be performed with a loss control pan.

### CEMOS DIALOG optimises the quality of your crop.

You specify the level of crop quality you wish to obtain, CEMOS DIALOG asks for your target values and assists you with calibration of the GRAIN QUALITY CAMERA. The system then guides you step by step to the sought-after result.

Operating in the background, the GRAIN QUALITY CAMERA continuously analyses the harvested material for broken grains and non-grain constituents. You are kept informed at all times about the current quality of the crop. At the same time, CEMOS AUTO THRESHING uses the results of the analysis for continuous optimisation of the threshing unit settings.

# The LEXION: precision harvesting like never before.

## Keep the number of passes to a minimum.

Steering systems are an essential tool in your everyday work. The LEXION can be equipped with two automatic steering systems which you can choose between on the basis of the task in question: the digital AUTO PILOT and the satellite-based GPS PILOT CEMIS 1200.

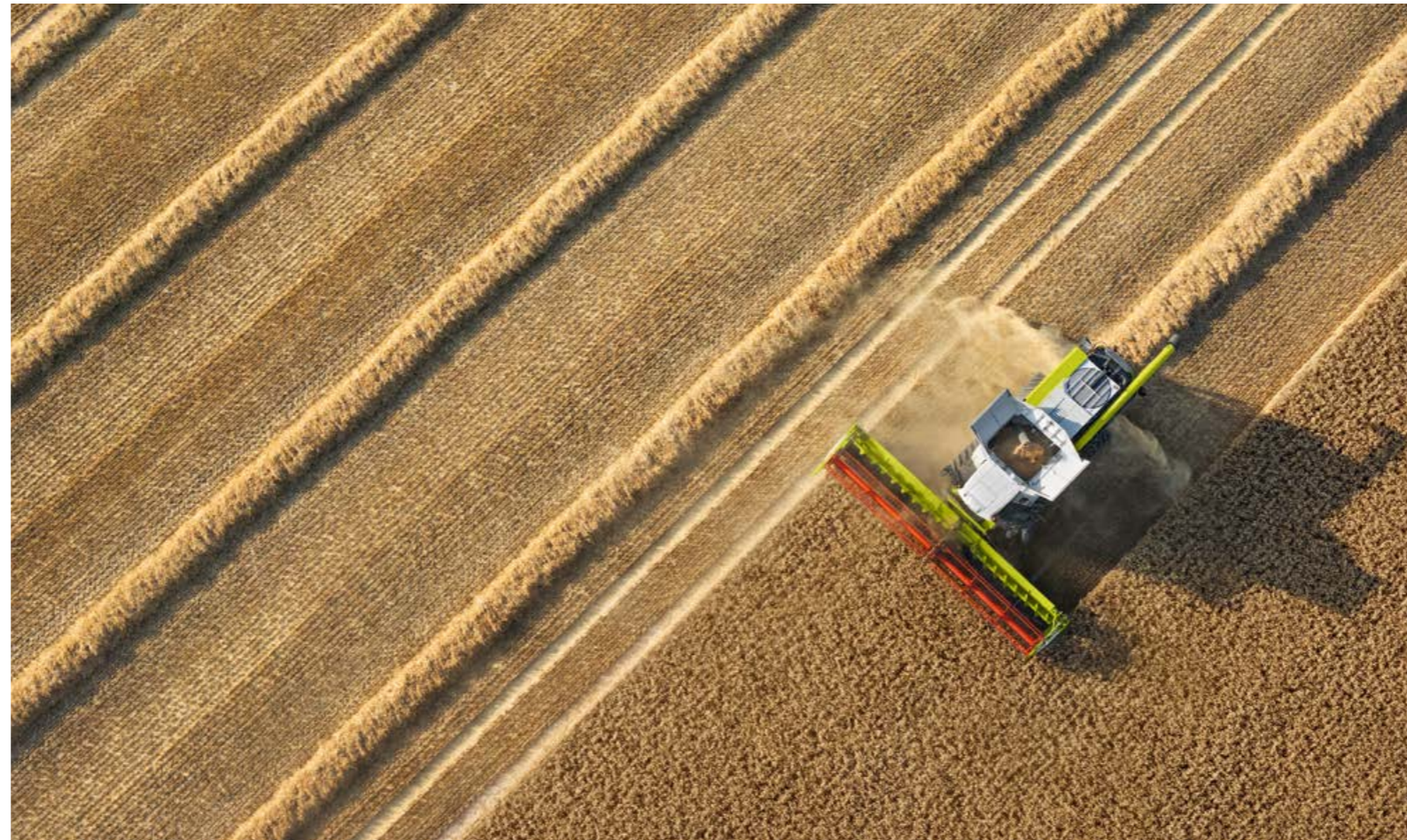

## Precision for every task.

- The GPS PILOT steers precisely and can be controlled intuitively via CEMIS 1200.
- The AUTO PILOT helps you work precisely in maize.
- With dynamic steering you can turn quickly and easily at the end of the field.

## GPS PILOT with unbeatable steering precision.

The satellite-based automatic steering system from CLAAS is permanently integrated in the machine. It supports you in all tasks which depend on high pass-to-pass accuracy. You start the GPS PILOT via the multifunction lever. It actively controls the steering hydraulics and guides you across the field precisely at all speeds, regardless of the light conditions. It works at night or in low visibility just as precisely as it does in full daylight. You receive correction signals for whichever degree of accuracy you require.

## CEMIS 1200 terminal with intuitive control.

With CEMIS 1200 you have an entirely new steering terminal in the cab of your combine harvester. You can count on its support for precision GPS tracking. It also allows you to handle all the common precision farming applications. You can map your yields in real time, manage your jobs and document them directly on the machine. You will be familiar with the control logic from your CEBIS. CEBIS 1200 can be controlled just as intuitively.

- The brilliant 12" display is easy to read by day or night.
- All the relevant functions are available with direct access.
- You can adapt the working areas in line with your requirements and configure them freely.

## AUTO PILOT.

Two digital sensors incorporated in one of the picking units of the maize picker guide the LEXION automatically through the rows of maize, thereby ensuring it is in the optimal position in the crop.



## Dynamic steering

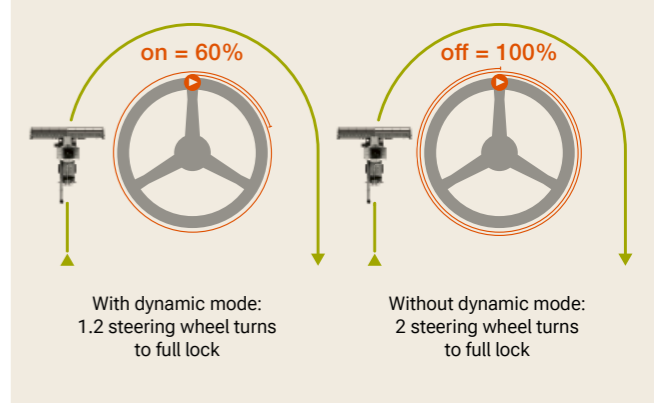

## Dynamic steering for fast turning.

You steer the LEXION with about four steering wheel turns from lock to lock. If you prefer a less demanding steering input when you have to turn at the end of the field, you can activate the dynamic steering system. This reduces by 40% the extent to which the steering wheel has to be turned to go from straight-ahead running to full lock. This functionality is conditional on a speed of less than 10 km/h.



# A connected LEXION is more productive.

## Digitalisation pays.

Intelligent digitalisation matched to the requirements of your farm reduces your workload and increases your productivity. Data generated in completely different places can be collected and evaluated centrally. This conserves your resources and improves your farm operations.

To enable you to get more out of the LEXION and your other machines, CLAAS offers a range of modules which allow systems, technology and working processes to be connected with each other, regardless of the manufacturer.

## Forward planning in the office.

- Use CLAAS connect to determine the harvest sequence per crop on the basis of maturation
- Prepare jobs including reference tracks and transfer them to CEMIS 1200

## Optimisation on the machine.

- Create and manage all jobs directly on the machine with CEMIS 1200
- All job data are documented online as an automatic background operation
- Transmit data from different manufacturers' products into the cloud smoothly
- Use CLAAS connect and the CEMOS Advisor app to monitor the performance of the combine harvester and make full use of it
- Save valuable maintenance and service time with remote diagnostics

## Detailed assessment in the office.

- Transfer and document job and harvest data quickly
- Analyse fields easily and map yields precisely
- Assess work processes intensively and identify scope for improvement

## CLAAS connect. Your whole farm in an app.

Automatic documentation of machine and harvest data, connectivity functions, farm management solutions, parts, licences – with CLAAS connect you have the whole world of CLAAS in your pocket.

## More operational reliability.

You can view all service and maintenance data and have a direct connection with your dealer. It takes next to no time to find the operating instructions for your LEXION and to order consumables and parts<sup>1</sup> straight from your dealer.

## Complete machine overview.

No matter where you are, you can keep an eye on your machine's performance and see the expected completion time for the work in the field. You can optimise the settings of your LEXION with CEMOS Advisor.

<sup>1</sup> Shop offer may vary according to country

## Efficient job management.

Create jobs with a click in CEMIS 1200 and send them online to the field and back again.

## Clear yield maps.

The Geocenter takes care of creating your yield maps. You can find all geodata, maps and associated machine data clearly arranged in one place.

## Cross-brand fleet management.

It is easy to connect third-party machines via Data connect. The Connection Manager makes it possible to exchange and share all machine data.

## Two Connect packages to make your job easier.

The Connect packages get you on the right track to manage all your farm's digital tasks. Your CLAAS sales partner and digital specialist will set you up with all the functions you need for your business.

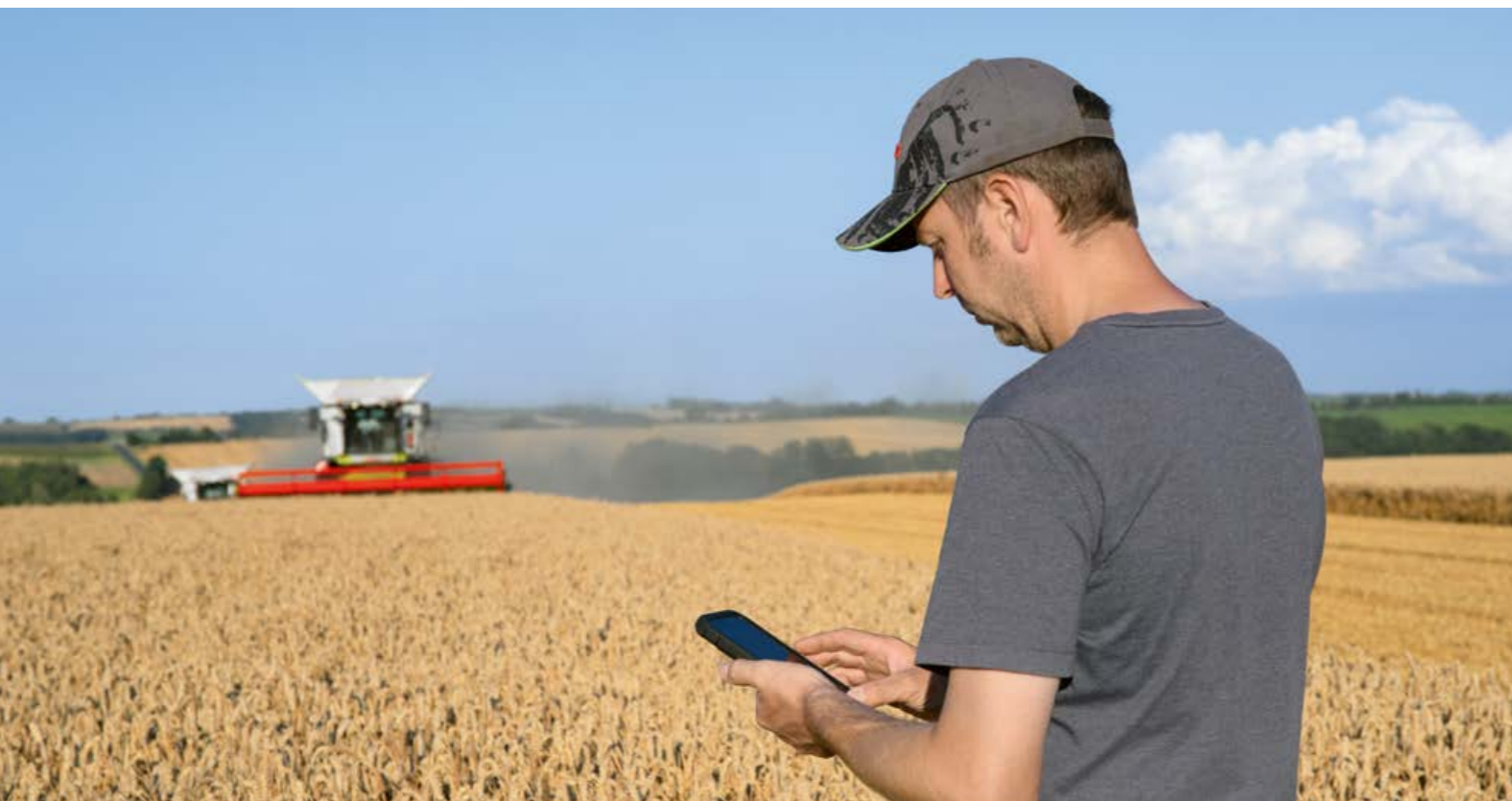

## CLAAS connect packages for combine harvesters.

<p><b>Connect Package</b></p>	<p><b>Document</b></p> <ul style="list-style-type: none"> <li>- CLAAS connect</li> <li>- Optional: farm licences for CLAAS connect</li> <li>- Machine connect</li> </ul>
<p><b>Connect Package PROFESSIONAL</b></p>	<p><b>Document, Steer, Precision farming</b></p> <ul style="list-style-type: none"> <li>- CLAAS connect</li> <li>- Optional: farm licences for CLAAS connect</li> <li>- Machine connect</li> <li>- GPS PILOT CEMIS 1200</li> <li>- TC Geo</li> </ul>

# Fast maintenance is crucial for your harvest.



## Reduced daily maintenance requirement.

Like all its predecessors, the LEXION is also appreciated for being a model of restraint where maintenance requirements are concerned. The maintenance intervals are long: 1,000 hours for the oil in the working hydraulics. Daily maintenance tasks can be carried out quickly and effortlessly. All the key maintenance points can be accessed easily.

## Reliable lubrication.

The central lubrication system supplies grease to all the lubrication service points, including the variators, as required. Lubrication points and intervals only need to be programmed once.



## Optimal accessibility.

The robust engine compartment cover makes it particularly easy for you to access the grain tank and to perform any maintenance tasks required there. It is slip-resistant and designed to be walked on. Handrails and a folding step provide additional safety.

- All the maintenance points around the machine are easily accessible.
- Contact points for the mobile ladder enable safe access for maintenance and cleaning tasks.
- The side panels, steps and engine compartment are brightly lit.
- A door provides easy access to the 18,000-litre grain tank.

## More time for harvesting.

- The centrally routed drain hoses for engine oil and hydraulic oil are easily accessible.
- All the variators are connected to the central lubrication system.
- The air compressor with a reservoir enables cleaning tasks to be performed quickly, even in the field.
- The grain tank can be accessed easily via the divided engine compartment cover which is designed to be walked on.

## Well thought-out convenience package.

The convenient maintenance package features a number of practical solutions to make daily maintenance tasks more user-friendly:

- Secure bracket for the grease gun
- Removable water tank with 15 litre capacity
- Separate drain cock for hand washing on side of tool compartment

## Automatic air hose reel.

The convenient maintenance package of the new LEXION also includes an air hose reel with a 15 m compressed air hose which can be unwound and wound up easily and tidily. The reel is locked as soon as you have unwound the hose. Pulling on the hose briefly causes it to be wound up again automatically. This feature makes fast interim cleaning in the course of the day even more convenient.



# The LEXION adapts quickly to changing requirements.



- 1 Threshing unit
- 2 Grain collection
- 3 Grain tank
- 4 Grain tank unloading
- 5 Secondary separation
- 6 Straw chopper knife
- 7 Radial spreader

## Conversion in next to no time.

Every minute the LEXION is not standing in the yard benefits your harvest. This applies not only to daily maintenance, but also to changeover tasks and the replacement of wear parts which you only have to perform from time to time. Changing the threshing concave or adjusting the speed of the threshing drum and straw chopper are typical examples. We have designed the LEXION in such a way that all these tasks require as little effort as possible.

## Replace wear parts less often.

All components subject to particularly heavy wear and tear in the crop flow are optionally available in PREMIUM LINE quality. These are the right choice when you have to harvest under extreme conditions which are particularly hard on your combine harvester.

PREMIUM LINE components are extra resistant to wear and corrosion and have a very long service life. Even with intensive annual use or when subjected to aggressive crops, these parts will not usually have to be changed until after several campaigns. This increased durability is achieved through special manufacturing processes, high-quality materials and special coatings.

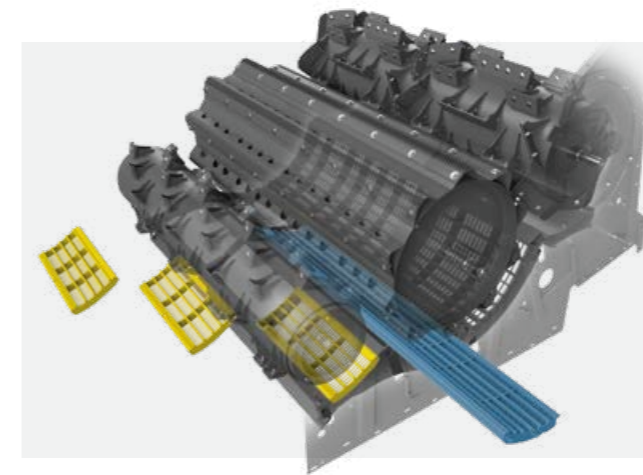

## Change concave segments more quickly.

When you want to change from one crop to another and prepare the LEXION for maize harvesting after the grain harvest, for example, you can look forward to short changeover times. The main components of the threshing concave remain in the machine. You can change the preconconcave segments quickly through the stone trap. The threshing concave segment is simply pulled out to the side.

## Speed adjustment without tools.

Depending on the crop, the threshing drum needs to run at different speeds. The threshing drum speed reduction gearbox allows you to change quickly between two speed ranges. In the low range, speeds from 170-460 rpm are available while the high range offers 330-930 rpm.

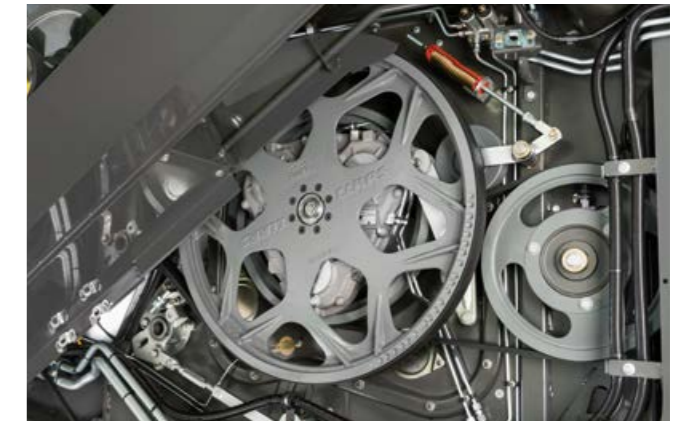

Even in the mechanical variant, the speed range can be adjusted without the need for tools. If you want to save even more time, choose the hydraulically adjustable version (optional). You can then perform the adjustment from the comfort of the cab.

## Simply leave the same straw chopper knives in the machine.

Adjusting the straw management system also takes next to no time. If you choose wear-resistant PREMIUM LINE chopper knives, you benefit from components with a long service life which require replacement less frequently.

## Universal chopper knives for grain and maize in PREMIUM LINE quality.

These wear-resistant chopper knives are suitable for both grain and maize harvesting. When you change crop, you can simply leave the same knives in the machine.

## Every minute is precious.

- Extra wear-resistant PREMIUM LINE components require less frequent replacement.
- The preconconcave segments are changed quickly through the stone trap.

- The threshing concave segment is simply pulled out to the side.
- You can adjust the threshing drum speed without tools or, with hydraulic assistance, from the cab (optional).
- When changing crop from grain to maize, the same chopper knives remain in the machine.

On call for you.

**Parts and services?**

**Everything, at  
the right time.**

**We're here for you – by your side to help achieve the best possible result.**

At CLAAS, keeping you operational is our top priority. With our comprehensive range of services, parts and consumables, we ensure that your machines always perform optimally.

Our support includes a wide range of maintenance and repair services available from your dealer, an extensive line-up of ORIGINAL parts and consumables as well as digital tools which support your planning and decision-making. Because keeping you operational is what really counts.

**Fully covered with MAXI CARE service contracts.**

MAXI CARE offers you all the repair and maintenance cover you need. This comprehensive range of contracts ensures that your machines are always operational so that you can concentrate fully on your main activities. CLAAS offers you a choice of four MAXI CARE service contracts tailored to the specific requirements of your business.





- |                                       |   |                                      |
|---------------------------------------|---|--------------------------------------|
| 1 Comfort cab                         | 7 ROTO PLUS secondary separation            | 13 DYNAMIC COOLING                   |
| 2 CEMOS AUTOMATIC                     | 8 Grain elevator with QUANTIMETER           | 14 MAN engines                       |
| 3 Feeder housing with dust extraction | 9 Grain tank with up to 18,000 l            | 15 Chaff fan                         |
| 4 APS SYNFLOW HYBRID threshing unit   | 10 Pivoting spout                           | 16 Radial spreader                   |
| 5 600 mm feeder drum                  | 11 Grain tank unloading at up to 180 l/s    | 17 TERRA TRAC with 40 km/h top speed |
| 6 JET STREAM cleaning                 | 12 Cover flap for grain tank unloading tube | 18 Separate returns pan              |
|                                       |   | 19 3D cleaning system                |



Machine of the year 2020



Agritechnica Innovation Award 2019: CEMOS AUTO CHOPPING



Agritechnica Innovation Award 2022: CEMOS AUTO HEADER



## Efficiency.

- APS SYNFLOW HYBRID revolutionises throughput.
- Large threshing and feeder drums provide a straight, even and fast crop flow.
- DYNAMIC COOLING provides cooling as required.
- DYNAMIC POWER for fuel savings of up to 10%.
- JET STREAM cleans your grain impeccably.
- 18,000 l unloaded in 100 s.
- 40 km/h gets you there quickly.
- CLAAS cutterbars deliver an optimal crop flow, right from the start.



## Precision.

- CEMOS AUTOMATIC continuously optimises threshing unit, cleaning system and crop flow.
- CEMOS AUTO THRESHING in CEBIS adjusts the threshing drum speed, threshing concave clearance, threshing concave bar and flap.
- AUTO SLOPE reduces your workload on slopes.
- GPS PILOT CEMIS 1200 keeps the number of passes to a minimum.
- CEMOS AUTO CHOPPING optimises the chopped material quality and reduces fuel consumption.
- CEMOS AUTO HEADER optimises the crop flow right from the cutterbar.
- CEMIS 1200 provides precise steering and precise documentation.
- Automatic documentation of your work and yield data with CLAAS connect
- Comparison and optimisation of machines in the field with CLAAS connect.



## Comfort.

- The comfort cab with its new air conditioning system provides plenty of headroom and legroom.
- The CEBIS touchscreen is as easy to use as your smartphone.
- Operation of the CMOTION multifunction lever is intuitive.
- The direct adjustment function in the armrest allows you to access the most important functions.
- You can react quickly to crop type changes.
- The 105° pivot angle improves the view of the grain tank unloading tube.
- LED lighting packages turn night into day.
- The pivoting spout on the grain tank unloading tube directs the stream precisely.



## Reliability.

- The revised drive system impresses with its high efficiency.
- The main drive engages gently via the dry clutch.
- The central lubrication system supplies all lubrication points, including the variators.
- PREMIUM LINE components are extra resistant to wear and have a very long service life.
- Flexible MAXI CARE service products increase operational reliability.
- Remote Service simplifies maintenance and service support.
- All the maintenance points around the machine are easily accessible.



LEXION LEXION TERRA TRAC (TT)			8800 / 8800 TT	8700 / 8700 TT	8600 / 8600 TT	7700 / 7700 TT	7600 / 7600 TT
Drive axle tyre size		ø cat.	External width				
VF 900/60 R 42 CFO	m	2.15	3.90	3.9	–	3.62	–
900/60 R 42 CHO	m	2.15	3.90	3.9	–	3.62	–
800/70 R 42 CHO	m	2.15	3.76	3.76	–	3.48	–
680/80 R 42 CHO	m	2.15	3.49	3.49	–	3.22	–
VF 900/60 R 38 CHO	m	2.05	3.90	3.90	3.90	3.62	3.62
900/60 R 38 CHO	m	2.05	3.90	3.90	3.90	3.62	3.62
IF 800/70 R38 CFO	m	2.05	3.76	3.76	3.76	3.48	3.48
800/70 R 38 CHO	m	2.05	3.76	3.76	3.76	3.48	3.48
680/80 R 38 CHO	m	2.05	3.49	3.49	3.49	3.22	3.22
900/60 R 32	m	1.95	–	3.90	3.90	3.62	3.62
IF 800/70 R 32 CFO	m	1.95	–	3.76	3.76	–	3.48
800/70 R 32	m	1.95	–	3.76	3.76	3.48	3.48
710/75 R 34	m	1.95	–	–	3.65	3.37	3.37
IF 680/85 R 32 CFO	m	1.95	–	3.49	3.49	–	3.20
680/85 R32	m	1.95	–	3.49	3.49	3.20	3.20
TERRA TRAC 635 mm	m	–	3.49	3.49	3.49	3.29	3.29
TERRA TRAC 735 mm	m	–	3.79	3.79	3.79	3.49	3.49
TERRA TRAC 890 mm	m	–	3.99	3.99	3.99	3.79	3.79
Steering axle tyre size		ø cat.	External width				
710/60 R 30	m	1.65	3.89	3.89	3.89	3.69	3.69
VF 620/70 R 30	m	1.65	3.69	3.69	3.69	3.49	3.49
620/70 R 30	m	1.65	3.69	3.69	3.69	3.49	3.49
VF 520/85 R 30	m	1.65	3.49	3.49	3.49	3.29	3.29
500/85 R 30	m	1.65	3.47	3.47	3.47	3.27	3.27
500/85 R 34	m	1.75	3.47	3.47	–	–	–
VF 500/85 R 34	m	1.75	3.47	3.47	–	–	–
VF620/70 R 26	m	1.50	–	–	–	3.49	3.49
600/65 R 28	m	1.50	–	–	–	3.69	3.49
500/85 R 24	m	1.50	–	–	–	3.48	3.28
Front attachments							
VARIO cutterbars			VARIO 1380 <sup>1</sup> , VARIO 1230, VARIO 1080, VARIO 930, VARIO 770, VARIO 680				
CERIO cutterbars			CERIO 930, CERIO 770, CERIO 680				
Rapeseed equipment			For all CONVIO and VARIO cutterbars, not available for CERIO cutterbars				
Folding cutterbars			C 540				
ROVIO maize pickers	rows		12, 8, 6				
SUNSPEED	rows		1200, 940, 750				
MAFLEX			MAXFLEX 930, MAXFLEX 770				
CONVIO FLEX			CONVIO FLEX 1530 <sup>1</sup> , CONVIO FLEX 1380 <sup>1</sup> , CONVIO FLEX 1230, CONVIO FLEX 1080, CONVIO FLEX 930, CONVIO FLEX 770				
CONVIO			CONVIO 1380 <sup>1</sup> , CONVIO 1230, CONVIO 1080, CONVIO 930, CONVIO 770				
VARIO rice cutterbars			Available as HD version with rice harvesting accessory pack				
CERIO rice cutterbars			Available as HD version with rice harvesting accessory pack				
SWATH UP			SWATH UP 450				
Front attachment variable speed drive (electrohydraulic)	rpm		284-420				
Front attachment step drive	rpm		332, 420				
Instant cutterbar brake			○				

<sup>1</sup> Only for LEXION with TERRA TRAC

● Standard ○ Option □ Available – Not available

LEXION LEXION TERRA TRAC (TT)		8800 / 8800 TT	8700 / 8700 TT	8600 / 8600 TT	7700 / 7700 TT	7600 / 7600 TT
Threshing unit and primary separation						
APS SYNFLOW HYBRID		●	●	●	●	●
Threshing drum width	mm	1700	1700	1700	1420	1420
Threshing drum diameter	mm	755	755	755	755	755
Threshing drum speed	rpm	330-930	330-930	330-930	330-930	330-930
With reduction gear	rpm	170-460 / 330-930	170-460 / 330-930	170-460 / 330-930	170-460 / 330-930	170-460 / 330-930
Threshing concave wrap angle	degrees	132	132	132	132	132
Main concave area	m <sup>2</sup>	1.55	1.55	1.55	1.30	1.30
Rice threshing unit		○	○	○	○	○
Secondary separation						
ROTO PLUS high performance rotors	No.	2	2	2	2	2
Feed drum diameter	mm	600	600	600	600	600
Rotor length	mm	4200	4200	4200	4200	4200
Rotor diameter	mm	445	445	445	445	445
Rotor concaves	No.	6	6	6	5	5
Rotor speed	rpm	450-1250	450-1250	450-1250	370-1050	370-1050
Cleaning						
JET STREAM		●	●	●	●	●
Turbine fan		8-way	8-way	8-way	6-way	6-way
Fan adjustment, hydraulic		●	●	●	●	●
Dual ventilated step		●	●	●	●	●
4D cleaning system		○	○	○	○	○
Total sieve area	m <sup>2</sup>	6.20	6.20	6.20	5.10	5.10
Returns display in CEBIS		○	○	○	○	○
GRAINMETER		○	○	○	○	○
Grain tank						
Capacity (as per ANSI/ASAE S312.2)	l	15000 / 18000	15000 / 18000	13500 / 15000	13500 / 12500	12500 / 13500
Unloading auger swivel angle	degrees	105	105	105	105	105
Pivoting unloading spout		○	○	○	○	○
Unloading rate	l/s	130/180	130/180	130/180	130/180	110/130
QUANTIMETER yield meter		○	○	○	○	○
Chopper						
SPECIAL CUT straw chopper, knives	No.	108	108	108	72	72
STANDARD CUT straw chopper, knives	No.	64	64	64	52	52
Radial spreader		○	○	○	○	○
Hydraulic changeover from cab (road travel, swathing, chopping)		●	●	●	●	●
Hydraulic adjustment of static knife and friction concave plate		○	○	○	○	○
Chaff spreader		○	○	○	○	○
Chaff fan with radial spreader		○	○	○	○	○
Automatic discharge direction adjustment		○	○	○	○	○

● Standard ○ Option □ Available – Not available

LEXION LEXION TERRA TRAC (TT)		8800 / 8800 TT	8700 / 8700 TT	8600/ 8600 TT	7700 / 7700 TT	7600 / 7600 TT
Chassis						
TERRA TRAC crawler tracks with hydropneumatic suspension		○	○	○	○	○
POWER TRAC 4-wheel drive		○	○	○	○	○
2-speed manual gearbox		●	●	●	●	●
40 km/h		○	○	○	○	○
Differential lock for wheeled machine		○	○	○	○	–
Car-like driving characteristics		●	●	●	●	●
Engine Stage III A / Tier 3						
Manufacturer / Type		MAN D42	MAN D38	MAN D38	MAN D26	MAN D26
Cylinders / displacement	No./l	6/16.2	6/15.3	6/15.3	6/12.4	6/12.4
Maximum output (ECE R 120)	kW/hp	515/700	475/646	440/598	404/549	373/507
Fuel consumption measurement		○	○	○	○	○
Fuel tank capacity	l	1150	1150	1150	1150	1150
DYNAMIC COOLING		●	●	●	●	●
DYNAMIC POWER		●	●	●	●	●
Data management						
Machine connect – 5-year licence		●	●	●	●	●
Job management		○	○	○	○	○
Yield mapping		○	○	○	○	○
Operator assistance systems						
CRUISE PILOT		○	○	○	○	○
CEMOS AUTO THRESHING		○	○	○	○	○
CEMOS AUTO CLEANING		○	○	○	○	○
CEMOS AUTO SEPARATION		○	○	○	○	○
CEMOS AUTO CHOPPING		○	○	○	○	○
CEMOS AUTO HEADER		○	○	○	○	○
AUTO SLOPE		○	○	○	○	○
AUTO CROP FLOW		○	○	○	○	○
CEMOS DIALOG		○	○	○	○	○
GRAIN QUALITY CAMERA		○	○	○	○	○
Steering systems						
GPS PILOT CEMIS 1200, AUTO PILOT		○	○	○	○	○
Weights (can vary depending on equipment) without front attachment, straw chopper and chaff spreader, full fuel tank	kg	19900 / 22400 (TT)	19700 / 22300 (TT)	19700 / 22300 (TT)	18700 / 20900 (TT)	18300 / 21400 (TT)

CLAAS continually develops its products to meet customer requirements. This means that all products are subject to change without notice. All descriptions and specifications in this brochure should be considered approximate and may include optional equipment that is not part of the standard specifications. This brochure is designed for worldwide use. Please refer to your nearest CLAAS dealer and their price list for local specification details. Some protective panels may have been removed to present the function more clearly in photographs. To avoid any risks, you should never remove these protective panels yourself. In this context, please refer to the relevant instructions in the operator's manual.

All technical specifications relating to engines are based on the European emission regulation standards: Stage. Any reference to the Tier standards in this document is intended solely for information purposes and ease of understanding. It does not imply approval for regions in which emissions are regulated by Tier.

● Standard ○ Option □ Available – Not available

# We want to make you the best in your field.

In everything we do, the focus is on you, our customers. We understand your daily challenges. Together with you, we develop agricultural technology ensuring you can farm successfully and sustainably today and in the future. Our digital solutions simplify complex processes and make your work so much more convenient.



CLAAS KGaA mbH  
Mühlenwinkel 1  
33428 Harsewinkel  
Deutschland  
Tel. +49 5247 12-0  
[claas.com](http://claas.com)